

Jeans Pocket Setter

ジーンズポケットセッター

AP-876

PARTS LIST

CSTMP

HOW TO MAKE USE OF THIS PARTS LIST

- 1.As to “#01” and “#02” refer to the “Note” given at the bottom of the respective pages.
- 2.Codes on the “Qty” column
 - Each numeral indicates the number of parts required.
 - “0.1” and “2.5” indicate the length (in meters) of the respective parts.
- 3.Parentheses mean that the corresponding part is a subpart that constructs an assembly part.
- 4.Dotted lines on the Figures indicate assembly parts.
- 5.As to the parts with marks of “☆”(Consumable parts)and “◎”(optional parts)on the respective parts, it is recommended to prepare spares.

パーツリストご利用に際して

1. リストページの #01、#02 の印は、ページ下の “注記” の説明を参照下さい。
2. 数量欄の数字は、個数を表し、0.1、2.5 等の数値は、長さ（単位メートル）を表します。
3. 数量欄の（ ）は、組部品を構成している子部品であることを意味します。
4. イラストページの-----枠は、組構成であることを意味します。
5. リストページの “☆”（消耗部品）、“◎”（オプション部品）の印がついた部品は、予備を準備しておくことをお奨めします。

CSMP

CONTENTS

目次

1. FRAME & MICELLANEOUS COVER COMPONENTS.....	1
頭部・外装関係	
2. MAIN SHAFT COMPONENTS.....	3
上軸関係	
3. ARM SHAFT COMPONENTS.....	5
立軸関係	
4. NEEDLE BAR COMPONENTS (1).....	7
針棒関係 (1)	
5. NEEDLE BAR COMPONENTS (2).....	9
針棒関係 (2)	
6. PRESSER MECHANISM COMPONENTS.....	11
中押え関係	
7. THREAD TENSION COMPONENTS.....	13
糸調子関係	
8. SHUTTLE DRIVER SHAFT COMPONENTS.....	15
下軸関係	
9. THREAD TRIMMER MECHANISM COMPONENTS (1).....	17
糸切り関係 (1)	
10. THREAD TRIMMER MECHANISM COMPONENTS (2).....	19
糸切り関係 (2)	
11. LUBRICATION COMPONENTS (1).....	21
給油関係 (1)	
12. LUBRICATION COMPONENTS (2).....	23
給油関係 (2)	
13. MAIN BODY COVER COMPONENTS (1).....	25
装置外装関係 (1)	
14. MAIN BODY COVER COMPONENTS (2).....	27
装置外装関係 (2)	
15. FRAME COVER COMPONENTS.....	29
外装カバー関係	
16. MAIN BODY FRAME COMPONENTS.....	31
フレーム関係	
17. X-Y DRIVER UNIT (1).....	33
X - Y 駆動機構 (1)	
18. X-Y DRIVER UNIT (2).....	35
X - Y 駆動機構 (2)	
19. CLOTH PRESSER COMPONENTS.....	37
布押え関係	
20. FITTING PLATE COMPONENTS.....	39
折り機関係	

21. FORM PLATE MECHANISM COMPONENTS.....	41
型板機構関係	
22. VERTICAL TABLE COMPONENTS.....	43
テーブル上下機構関係	
23. SUCTION DEVICE COMPONENTS.....	45
吸引装置関係	
24. AIR PRESSURE COMPONENTS.....	47
空圧関係	
25. BOBBIN WINDER COMPONENTS.....	49
糸巻装置関係	
26. STACKER COMPONENTS.....	51
スタッカー関係	
27. CREASE GAGE COMPONENTS.....	53
折りゲージ関係	
28. FORM PLATE GAGE COMPONENTS.....	55
型板ゲージ関係	
29. PRESSER GAGE COMPONENTS.....	57
押えゲージ関係	
30. OPERATION PANEL COMPONENTS.....	59
操作パネル関係	
31. CONTROL BOX COMPONENTS.....	61
電装ボックス関係	
32. WIRING DIAGRAM (1).....	63
電装配線図 (1)	
33. WIRING DIAGRAM (2).....	65
電装配線図 (2)	
34. THREAD STAND COMPONENTS.....	67
糸立装置関係	
35. ACCESSORIES COMPONENTS.....	69
付属品関係	
36. MARKING LIGHT COMPONENTS (OPTION).....	71
マーキングライト関係 (オプション)	
37. GARMENT PUT BASE COMPONENTS (OPTION).....	73
身頃置き台関係 (オプション)	
38. BAR CODE READER (OPTION).....	75
バーコードリーダー (オプション)	
NUMERICAL INDEX OF PARTS.....	76
索引	

1. FRAME & MICELLANEOUS COVER COMPONENTS

頭部・外装関係

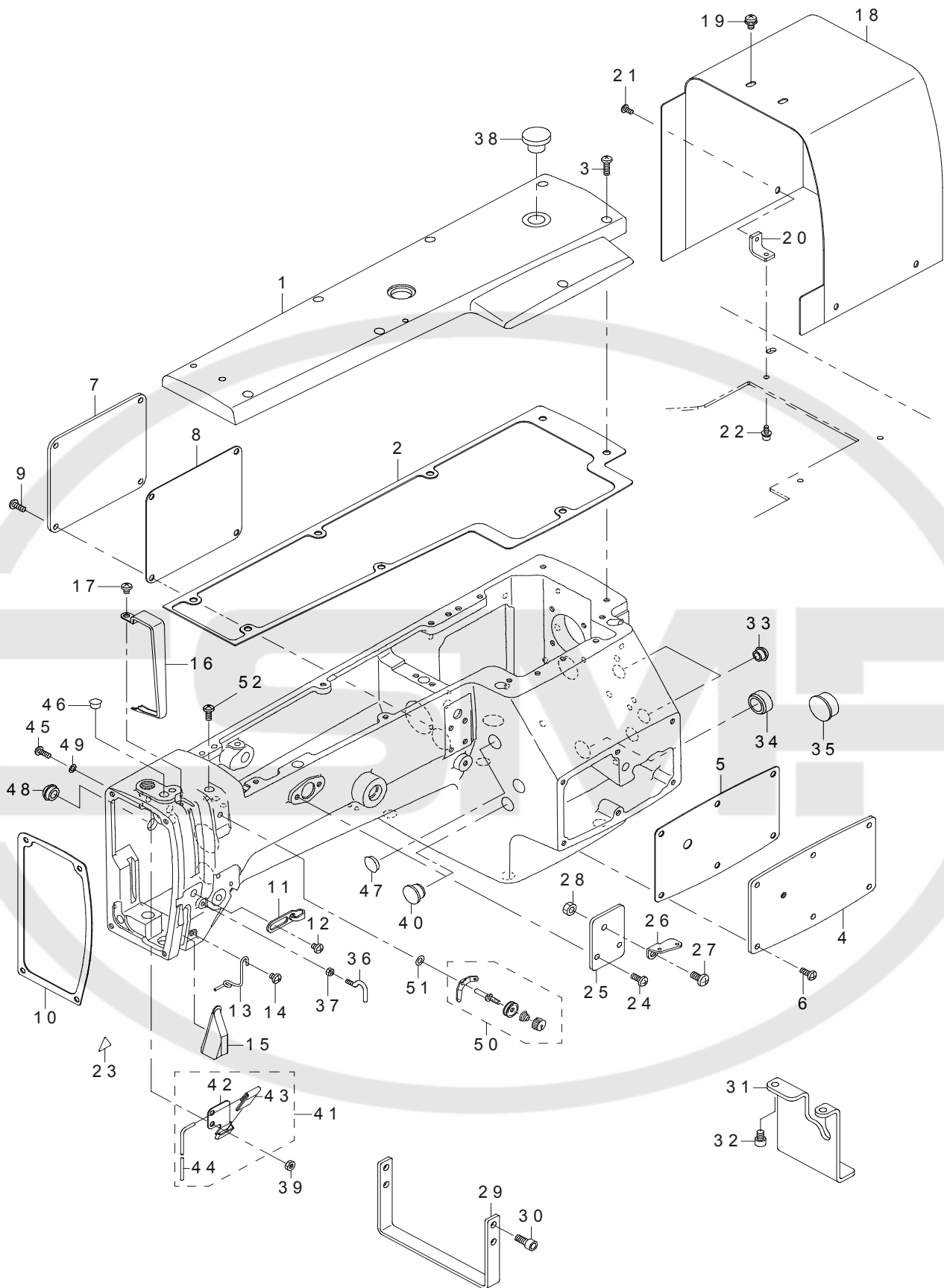

REF.NO	NOTE	PART NO	DESCRIPTION	品名	Qty
1		G1113-875-000	TOP COVER	上面カバー	1
2		G1119-875-000	UPPER FACE COVER PACKING	上面カバーパッキン	1
3		SS-4121215-SP	SCREW 3/16-28 L=12	なべねじ 3/16-28 L=12	8
4		G1111-875-000	ARM COVER A	アームカバー A	1
5		G1117-875-000	ARM COVER PACKING A	アームカバーパッキン A	1
6		SS-4121215-SP	SCREW 3/16-28 L=12	なべねじ 3/16-28 L=12	6
7		G1112-875-000	ARM COVER B	アームカバー B	1
8		G1118-875-000	ARM COVER PACKING B	アームカバーパッキン B	1
9		SS-4121215-SP	SCREW 3/16-28 L=12	なべねじ 3/16-28 L=12	4
10		G1116-875-000	FACE PLATE PACKING	面部パッキン	1
11	☆	139-22208	TAKE-UP THREAD GUIDE B	天秤糸案内 B	1
12		SS-4120615-SP	SCREW 3/16-28 L=6	なべねじ 3/16-28 L=6	1
13	☆	137-19802	NEEDLE BAR THREAD GUIDE	針棒糸案内 A	1
14		SS-4120615-SP	SCREW 3/16-28 L=6	なべねじ 3/16-28 L=6	1
15		137-05207	THREAD PATH GUIDE PLATE	糸道案内板	1
16		139-20509	THREAD TAKE-UP COVER	天秤カバー	1
17		SS-4120615-SP	SCREW 3/16-28 L=6	なべねじ 3/16-28 L=6	1
18		401-16251	MOTOR COVER	モータカバー	1
19		SL-4051091-SC	SCREW M5 L=10	座金付きなべ小ねじ M5 L=10	2
20		400-75985	COVER ANGLE	カバー支え	3
21		SM-0040801-SC	SCREW M4X8	トラスねじ M4 X 8	3
22		SL-6041092-TN	SCREW M4 L=10	座金付き六角穴ボルト M4 L=10	3
23		CM-3002000-01	FINGER INJURY CAUTION LABEL (16)	指怪我注意シール (16)	1
24		SS-4121215-SP	SCREW 3/16-28 L=12	なべねじ 3/16-28 L=12	2
25		401-16229	THREAD GUIDE PLATE A	糸案内板 A	1
26	☆	262-11904	THREAD GUIDE PLATE	第2糸案内	1
27		SM-4061255-SP	SCREW M6 L=12	なべねじ M6 L=12	1
28		NM-6060001-SC	NUT M6X1 TYPE1	六角ナット M6 X 1 1種	1
29		401-16230	HEAD STAND FRONT	頭部スタンド前	1
30		SS-6151412-TP	SCREW 15/64-28 L=14	六角穴ボルト 15/64-28	4
31		401-16231	HEAD STAND BACK	頭部スタンド後	1
32		SS-6151412-TP	SCREW 15/64-28 L=14	六角穴ボルト 15/64-28	2
33		TA-1050504-R0	RUBBER PLUG	止め栓	2
34		TA-2101002-R0	RUBBER PLUG	止め栓	1
35		TA-2351004-R0	RUBBER PLUG	止め栓	1
36	☆	262-12209	L-SHAPED THREAD GUIDE A	L型糸案内	1
37		NS-6090310-SP	NUT 9/64-40	六角ナット 9/64-40	1
38		G1135-870-000	OIL PLUG	オイル栓	1
39		NS-6110350-SP	NUT 11/64-40	六角ナット 11/64-40	2
40		TA-1470704-R0	RUBBER PLUG	止め栓	1
41		G3532-875-0A0	OIL WICK PRESSER ASM.	天秤クランク油芯押え組	1
42		B3502-210-000	OIL WICK HOLDER	油芯押え	(1)
43		B3509-220-000	OIL SPONGE	針棒クランク給油パイリン	(1)
44		CQ-2520000-00	OIL WICK	油芯	(0.2)
45		SS-4111215-SP	SCREW 11/64-40 L=12	なべねじ 11/64-40 L=12	2
46		TA-0850604-R0	RUBBER PLUG	止め栓	3
47		TA-1450404-R0	RUBBER PLUG D=14.5 L=4	止め栓 D=14.5 L=4	2
48		TA-1250406-R0	RUBBER PLUG D=12.5 L=4	止め栓 D=12.5 L=4	1
49		WP-0480856-SP	WASHER 4.8X8.4X0.8	平座金 4.8 X 8.4 X 0.8	2
50		110-73954	THREAD TENSION ASM.	第一糸調子組	1
51		WP-0531001-SC	WASHER	平座金みがき丸 M5	1
52		SS-4121215-SP	SCREW 3/16-28 L=12	なべねじ 3/16-28 L=12	1

REF.NO	NOTE	PART NO	DESCRIPTION	品名	Qty
1		401-16233	MAIN SHAFT	上軸	1
2		B1213-552-000-A	OIL ADJUSTING PIN	クランク油量調節ピン	1
3		B1226-552-000	ROLLER FELT	フェルト	1
4		B1215-552-000	OIL ADJUSTING COLLAR	クランク油量調節カラー	1
5		229-03157	COUNTER WEIGHT ASM.	釣合錘 (組)	1
6		SS-8660610-TP	SCREW 1/4-40 L=6	止めねじ 1/4-40 L=6	(2)
7		SS-8681650-TP	SCREW 9/32-28 L=16	止めねじ 9/32-28 L=16	(1)
8		SS-7681650-TP	SCREW 9/32-28 L=16	丸平ねじ 9/32-28 L=16	(1)
9		229-03108	COUNTER WEIGHT	釣合錘	(1)
10		RO-0442401-00	O-RING	Oリング	(1)
11		G1206-875-000	MAIN SHAFT BUSHING, FRONT	上軸前メタル	1
12		SS-8150822-TP	SCREW 15/64-28 L=8	止めねじ 15/64-28 L=8	1
13		G1212-870-0A0	UPPER BEVEL ARM ASM.	上傘歯車 A 組	1
14		SS-8660810-TP	SCREW 1/4-40 L=8	止めねじ 1/4-40 L=8	(2)
15		B1220-771-000	THRUST WASHER A	上軸スラストワッシャー A	4
16		B1211-980-000	UPPER SHAFT THRUST BEARING	上軸スラストベアリング	2
17		CS-150101A-TH	THRUST COLLAR ASM. D=15 W=10	スラスト受 D=15 W=10 組	2
18		SS-8660530-TP	SCREW 1/4-40 L=4.5	止めねじ 1/4-40 L=4.5	(2)
19		139-22901	MAIN SHAFT BUSHING, INTER	上軸中メタル	1
20		SS-8150822-TP	SCREW 15/64-28 L=8	止めねじ 15/64-28 L=8	1
21		G1220-870-000-A	OIL SHEEL	オイルシール	1
22		G1216-870-000	UPPER SHAFT REAR BEARING	上軸後ベアリング	1
23	☆	400-52937	550W SERVO MOTOR	550W サーボモータ	1
24		SL-6052592-TN	SCREW M5 L=25	座金付き六角穴ボルト M5 L=25	4
25	☆	401-16232	MOTOR MOUNT PACKING	モータ取付台パッキン	1
26		SS-6151612-TP	SCREW	六角穴ボルト	4
27		RO-0291801-00	RUBBER RING	Oリング	1
28		SQ-1110402-MZ	CONNECTING SCREW	チェーン連結ねじ	4
29		401-16034	MOTOR MOUNT	モータ取付台	1
30		401-16235	NEAR PULLEY SHAFT	手元プーリ軸	1
31		PS-0400142-KH	SPRING PIN 4X14	スプリングピン 4 X 14	1
32		B1212-210-D00	PULLEY	手元プーリ	1
33		A1230-500-000-A	HANDWHEEL SETSCREW	はずみ車止めねじ	1
34		D3902-481-C00-A	SPRING	繰出しマグばね	1
35		400-06516	GEAR B	ギア B	1
36		SM-8040310-SS	SCREW M4 L=3	止めねじ	2
37		B1144-210-000	REVOLVING DIRECTION LABEL	回転方向ラベル	1
38		137-07500	OIL SEAL	上軸前メタルオイルシール	2
39		400-06515	GEAR A	ギア A	1
40		SM-8040310-SS	SCREW M4 L=3	止めねじ	2
41		RO-1542401-00	O-RING	Oリング	1
42		236-04309	COUPLING	カップリング	1
43		SM-8060812-TP	SCREW M6 L=8	止めねじ M6 L=8	4
44		401-16234	OIL SEAL COLLER	オイルシールカラー	1
45		RO-1482402-00	O-RING	Oリング	1
46		SM-8050412-TP	SCREW M5 L=4	止めねじ M5 L=4	2

3. ARM SHAFT COMPONENTS

立軸関係

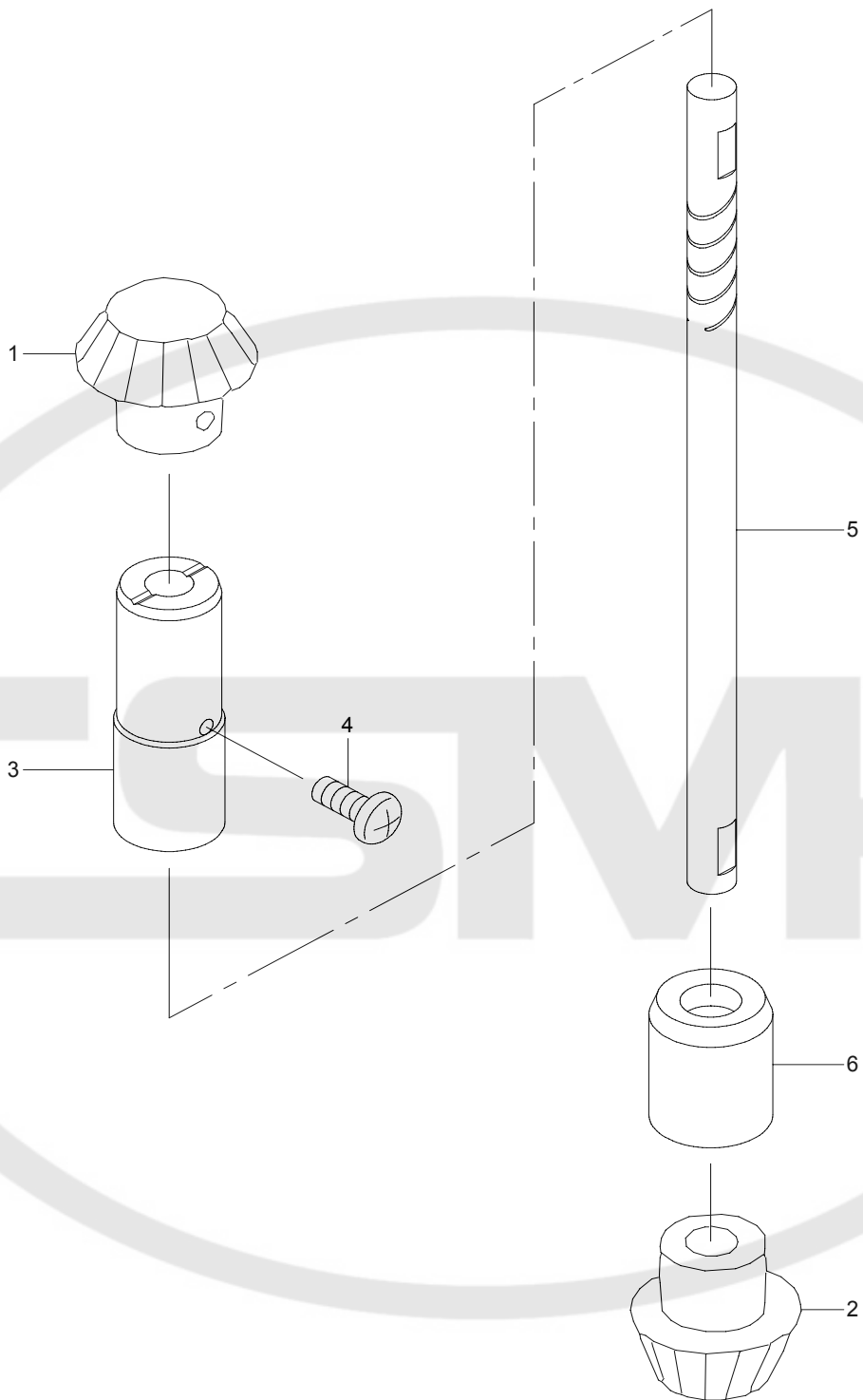

REF.NO	NOTE	PART NO	DESCRIPTION	品名	Qty
1		B1306-155-0A0	PINION ASM.	上傘歯車小組	1
2		B1307-155-0A0	GEAR ASM. LARGE	下傘歯車大組	1
3		G1302-875-000	VERTICAL SHAFT UPPER METAL	立軸上メタル	1
4		SS-4121215-SP	SCREW 3/16-28 L=12	なべねじ 3/16-28 L=12	1
5		G1301-875-000	VERTICAL SHAFT	立軸	1
6		110-042J5	UPRIGHT SHAFT BUSHING	立軸下メタル	1



4. NEEDLE BAR COMPONENTS (1)

針棒關係 (1)

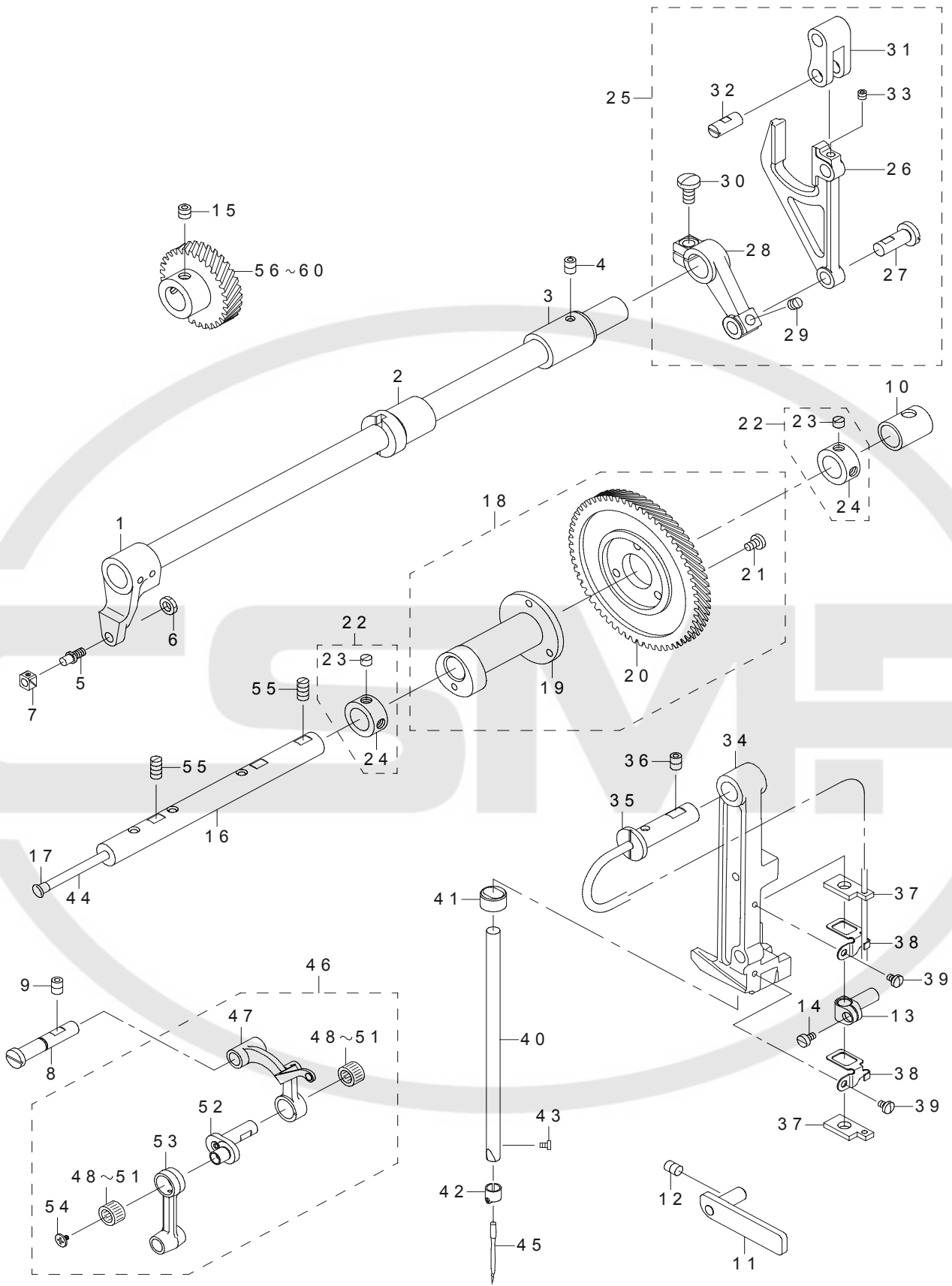

REF.NO	NOTE	PART NO	DESCRIPTION	品名	Qty
1		401-16236	NEEDLE BAR FRAME SHAFT ASM.	針棒揺動軸(組)	1
2		137-15404	BUSHING	針振り軸前メタル	1
3		137-15503	BUSHING, REAR	針棒揺動軸後メタル	1
4		SS-8150822-TP	SCREW 15/64-28 L=8	止めねじ 15/64-28 L=8	1
5		B1410-771-000	STUD	針棒揺動角ゴマ軸	1
6		NS-6150310-SP	NUT 15/64-28	六角ナット 15/64-28	1
7		B1414-232-000	SQUARE BLOCK	角ゴマ	1
8		137-30304	THREAD TAKE-UP SUPPORT ROD	天秤支え軸	1
9		SS-8150822-TP	SCREW 15/64-28 L=8	止めねじ 15/64-28 L=8	1
10		137-19000	BEARING, REAR B	揺動メタル	1
11		G1405-875-0A0	FRAME SUPPORT PLATE ASM.	揺動台支え板(組)	1
12		SS-8150822-TP	SCREW 15/64-28 L=8	止めねじ 15/64-28 L=8	1
13		139-24501	NEEDLE BAR CONNEC.	針棒抱き	1
14		SS-6090670-TP	SCREW 9/64-40 L=6	平ねじ 9/64-40 L=6	1
15		SS-8660612-TP	SCREW 1/4-40 L=6	止めねじ 1/4-40 L=6	2
16		137-18903	ROCK CAM SHAFT	揺動カム軸	1
17		TA-0550604-R0	RUBBER PLUG	止め栓	1
18		137-18754	NEEDLE BAR ROCK CAM CONNEC.	針棒揺動カム結合	1
19		137-18705	NEEDLE BAR ROCK CAM	針棒揺動カム	(1)
20		137-18804	NEEDLE THROW GEAR LARGE	針振駆動大歯車	(1)
21		SS-7110710-SP	SCREW 11/64-40 L=7	丸平ねじ 11/64-40 L=7	(3)
22		CS-140101A-SP	THRUST COLLAR ASM.	スラスト受組	2
23		SS-8150410-TP	SCREW 15/64-28 L=4.0	止めねじ 15/64-28 L=4	(4)
24		CS-1401014-SP	THRUST COLLAR	スラスト受	(2)
25		G1415-875-0A0	NEEDLE BAR FRAME ROD COMPL.	針棒揺動ロッド結合	1
26		G1415-875-000	NEEDLE BAR FRAME ROD	針棒揺動ロッド	(1)
27		137-15701	FRAME ROCK SHAFT CRANK PIN	針棒揺動腕後ピン	(1)
28		G1416-875-000	NEEDLE BAR ROCKING ARM, REAR	針棒揺動腕後	(1)
29		SS-8150510-TP	SCREW 15/64-28 L=4.7	止めねじ 15/64-28 L=4.7	(1)
30		SS-7151210-SP	SCREW 15/64-28 L=12	丸平ねじ 15/64-28 L=12	(1)
31		137-16006	CONNECTING FORKED LINK	二又揺動リンク	(1)
32		137-15909	CONNECTING FORKED LINK PIN	二又揺動リンクピン	(1)
33		SS-8110422-TP	SCREW 11/64-40 L=4	止めねじ 11/64-40 L=4	(1)
34		139-24600	NEEDLE BAR FRAME	針棒揺動台	1
35		137-14803	HINGE STUD	針棒揺動台軸	1
36		SS-8150822-TP	SCREW 15/64-28 L=8	止めねじ 15/64-28 L=8	1
37		137-14704	OIL FELT	針棒揺動台フェルト	2
38		139-25102	OIL FELT HOLDER	針棒揺動台フェルト押え	2
39		SS-7090530-SP	SCREW 9/64-40 L=4.5	丸平ねじ 9/64-40 L=4.5	2
40	☆	G1401-875-000	NEEDLE BAR	針棒	1
41		139-20608	NEEDLE BAR OIL METAL	針棒油メタル	1
42	☆	225-07701	THRED RACK, RIGHT	針棒糸掛け R	1
43	☆	SS-7080510-TP	SCREW 1/8-44 L=4.5	丸平ねじ 1/8-44 L=4.5	1
44		CQ-3000000-F0	OIL FELT	ロッドフェルト	0.1
45	☆	MC-2005313-00	NEEDLE 134 SERV7 NM130	針 134 SERV7 NM130	1
46	☆	G1902-875-0A0	LINK THREAD TAKE-UP LEVER ASM.	リンク天秤結合	1
47		110-17068	LINK THREAD TAKE-UP LEVER ASM.	リンク天秤組	(1)
48	#01	B1905-541-A00	NEEDLE BEARING, A	天秤ニードルベアリング	(2)
49	#01	B1905-541-B00	NEEDLE BEARING	天秤ニードルベアリング	(2)
50	#01	B1905-541-C00	NEEDLE BEARING	天秤ニードルベアリング	(2)
51	#01	B1905-541-D00	NEEDLE BEARING	天秤ニードルベアリング	(2)
52		110-91600	NEEDLE BAR CRANK H	針棒クランク H	(1)
53		137-14407	NEEDLE BAR CRANK ROD	針棒クランクロッド	(1)
54		B1903-552-000	LEFT SCREW	左ねじ	(1)
55		SS-8151230-SP	SCREW 15/64-28 L=12	止めねじ 15/64-28 L=12	2
56	#01	137-19109	NEEDLE THROW GEAR SMALL A	針振駆動小歯車 A	1
57	#01	137-19208	NEEDLE THROW GEAR SMALL B	針振駆動小歯車 B	1
58	#01	137-19307	NEEDLE THROW GEAR SMALL C	針振駆動小歯車 C	1
59	#01	137-19406	NEEDLE THROW GEAR SMALL D	針振駆動小歯車 D	1
60	#01	137-19505	NEEDLE THROW GEAR SMALL E	針振駆動小歯車 E	1
		NOTE(注記)	#01....SELECTIVE PARTS	選択部品	

5. NEEDLE BAR COMPONENTS (2)

針棒關係 (2)

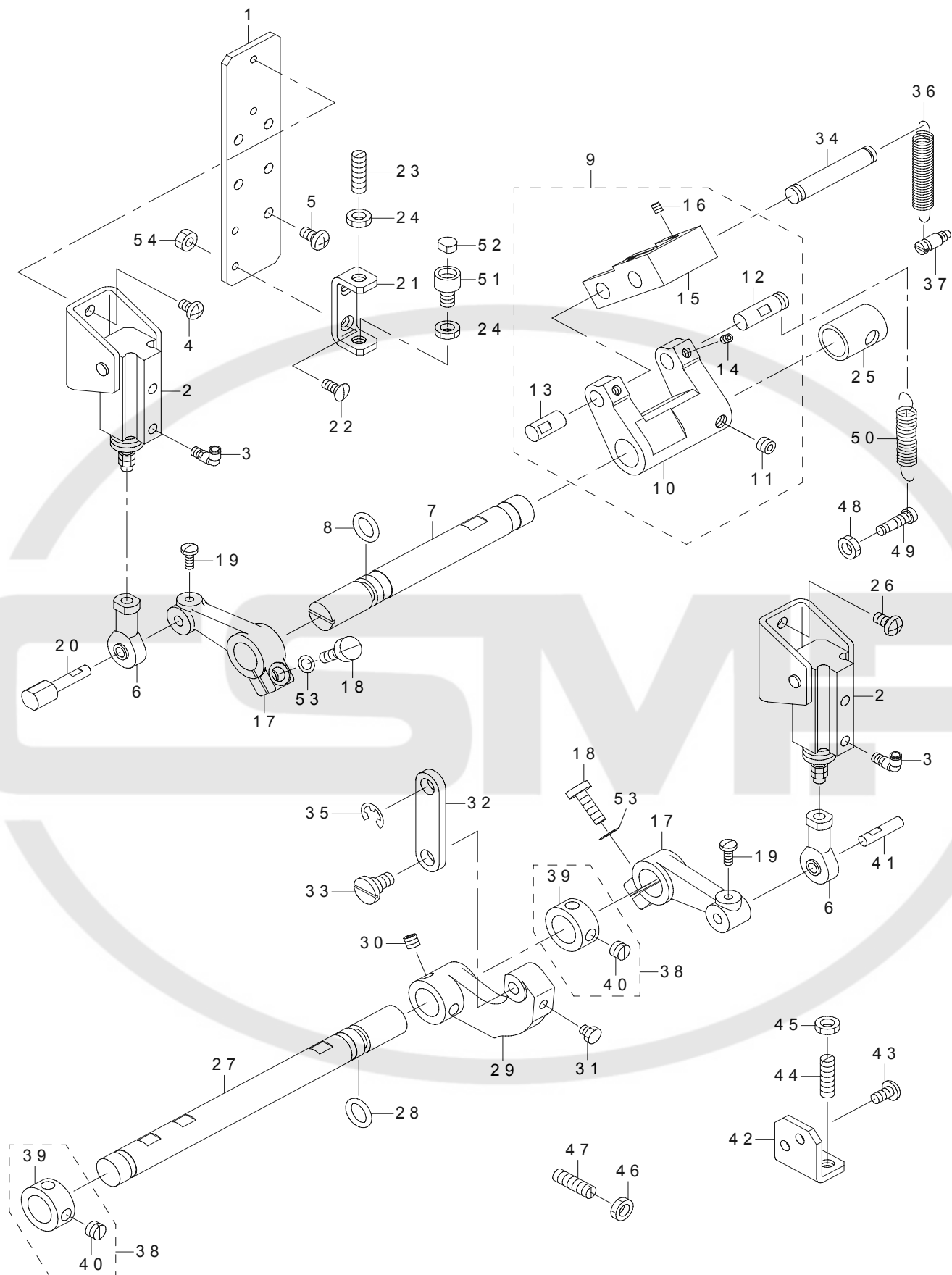

REF.NO	NOTE	PART NO	DESCRIPTION	品名	Qty
1		G1421-875-000	CYLINDER FITTING PLATE	基線シリンダ取付板	1
2		PA-1501010-A0	AIR CYLINDER	エアシリンダ	2
3		PJ-3040405-04	ELBOW UNION	エルボユニオン	4
4		SS-4110715-SP	SCREW 11/64-40 L=7	なべねじ 11/64-40 L=7	2
5		SS-4120915-SP	SCREW 3/16-28 L=9	なべねじ 3/16-28 L=9	5
6		G6505-880-000	ROD END B	ロッドエンドB	2
7		G1424-875-000	REPOSITIONING LEVER SHAFT	基線調節腕軸	1
8		RO-0982401-00	RUBBER RING	Oリング	1
9		400-55174	REPOSITIONING LEVER ASM.	基線調節腕結合	1
10		400-55176	REPOSITIONING LEVER	基線調節腕	(1)
11		SS-8660512-TP	SCREW 1/4-40 L=5	止めねじ 1/4-40 L=5	(2)
12		137-16303	REGULATING LEVER LINK STUD	振り巾変換リンク軸	(1)
13		G1431-875-000	REGULATING LEVER LINK STUD	振り巾変換リンク軸	(1)
14		SS-8110422-TP	SCREW 11/64-40 L=4	止めねじ 11/64-40 L=4	(2)
15		400-55175	REGULATING LEVER LINK	振り巾変換リンク	(1)
16		SS-8110422-TP	SCREW 11/64-40 L=4	止めねじ 11/64-40 L=4	(2)
17		G1426-875-000	REGULATING LEVER LINK STUD	基線振り巾腕	2
18		SS-9151630-CP	SCREW 15/64-28 L=15.5	六角ボルト 15/64-28	2
19		SS-7090920-SP	SCREW 9/64-40 L=8.5	丸平ねじ 9/64-40 L=8.5	2
20		G1422-875-000	REPOSITIONING CYLINDER SHAFT	基線シリンダ軸	1
21		G1423-875-000	REPOSITIONING STOPPER PLATE	基線ストッパ板	1
22		SS-2111010-TP	SCREW 11/64-40 L=9.5	丸皿ねじ 11/64-40 L=9.5	2
23		SS-8152030-SP	SCREW 15/64-28 L=20	止めねじ 15/64-28 L=20	1
24		NS-6150310-SP	NUT 15/64-28	六角ナット 15/64-28	2
25		137-19000	BEARING, REAR B	揺動メタル	1
26		SS-4120915-SP	SCREW 3/16-28 L=9	なべねじ 3/16-28 L=9	2
27		G1427-875-000	REGULATING LEVER SHAFT	振り巾調節腕軸	1
28		RO-0982401-00	RUBBER RING	Oリング	1
29		G1428-875-000	REGULATING LEVER	振り巾調節腕	1
30		SS-8660512-TP	SCREW 1/4-40 L=5	止めねじ 1/4-40 L=5	2
31		SS-9110513-TP	SCREW 11/64-40 L=5	六角ボルト 11/64-40 L=4.5	1
32		137-17004	REGULATING HINGE PIN	振り巾調節ロッド	1
33		SD-0800402-TP	HINGE SCREW D=8 H=4	段ねじ D=8 H=4	1
34		137-16105	CONNECTING STUD	二又揺動リンク軸	1
35		RE-0600000-K0	E-RING 6	E形止め輪6	1
36		137-17400	SPRING B	振り巾調節腕引張りばねB	1
37		B2006-372-000	ADJUSTING SCREW	糸調子調節かん案内軸	1
38		CS-140101A-SP	THRUST COLLAR ASM.	スラスト受組	2
39		CS-1401014-SP	THRUST COLLAR	スラスト受	(1)
40		SS-8150410-SP	SCREW 15/64-28 L=4	止めねじ 15/64-28 L=4	(2)
41		G1429-875-000	REGULATING CYLINDER SHAFT	振り巾シリンダ軸	1
42		G1430-875-000	REGULATING STOPPER PLATE	振り巾ストッパ板	1
43		SS-4120915-SP	SCREW 3/16-28 L=9	なべねじ 3/16-28 L=9	2
44		SS-8152030-SP	SCREW 15/64-28 L=20	止めねじ 15/64-28 L=20	1
45		NS-6150310-SP	NUT 15/64-28	六角ナット 15/64-28	1
46		NS-6150310-SP	NUT 15/64-28	六角ナット 15/64-28	1
47		SS-8152030-SP	SCREW 15/64-28 L=20	止めねじ 15/64-28 L=20	1
48		NS-6150310-SP	NUT 15/64-28	六角ナット 15/64-28	1
49		137-16907	SUSPENSION SCREW	基線調節ばね掛け	1
50		137-16808	SPRING	基線調節腕引張りばね	1
51		400-09095	SWING ARM STOPPER	振り巾調節腕ストッパ	1
52		B1432-761-000	SWING ARM STOPPER RUBBER	基線変換押し棒ブッシュ	1
53		WP-0621026-SP	WASHER 6.2X9.5X1	平座金 6.2 X 9.5 X 1	2
54		NS-6110420-SP	NUT 11/64-40	六角ナット 11/64-40	2

6. PRESSER MECHANISM COMPONENTS

中押え関係

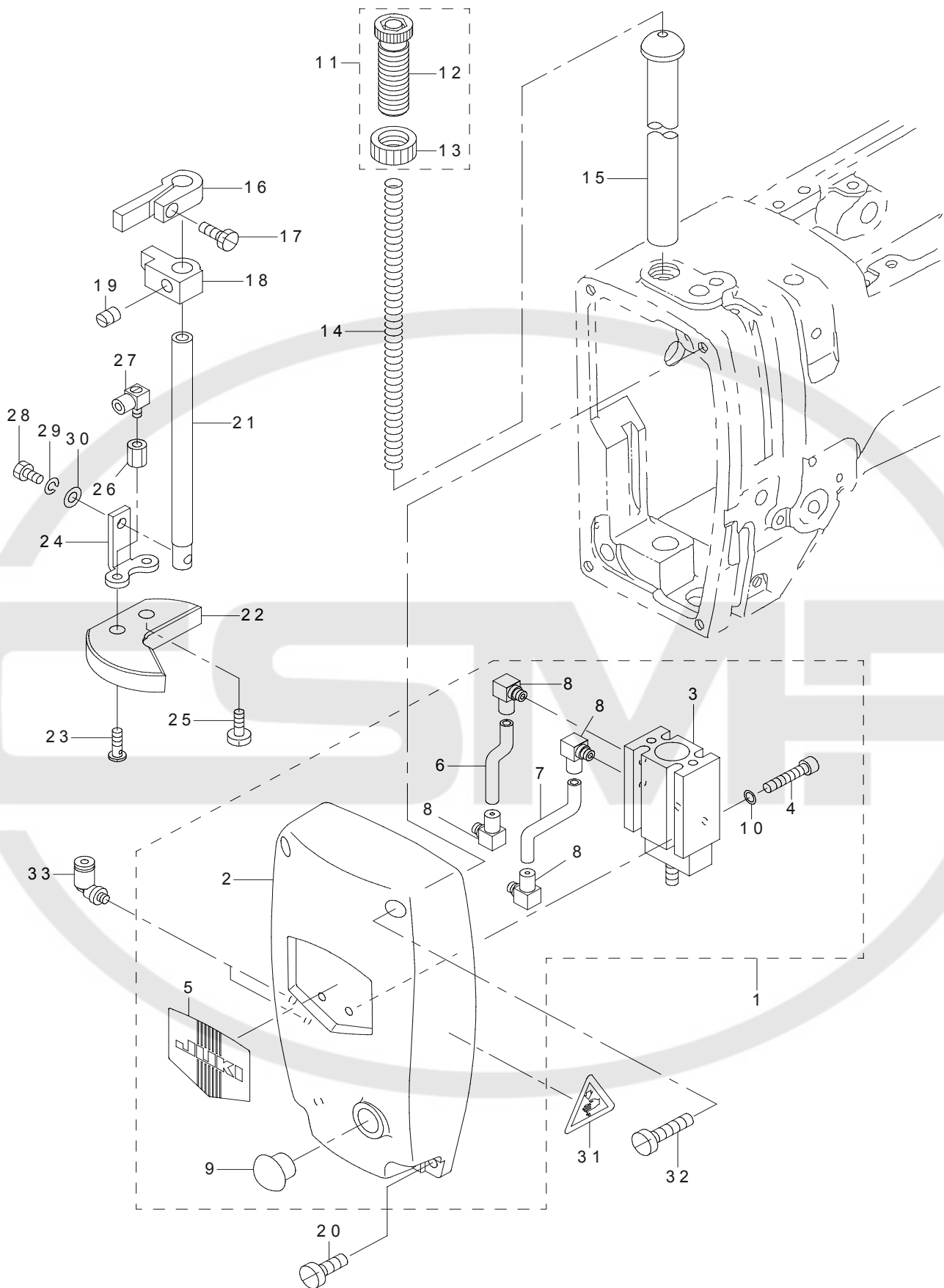

REF.NO	NOTE	PART NO	DESCRIPTION	品名	Qty
1		G1601-875-0A0	FACE COVER ASM.	面部カバー組	1
2		G1601-875-000	FACE COVER	面部カバー	(1)
3		PA-2002010-00	FREE-MOUNT CYLINDER	フリーマウントシリンダ	(1)
4		SM-6052502-TP	SCREW M5X0.8 L=25	六角穴ボルト	(1)
5		229-02506	FACE PLATE	面板化粧板	(1)
6		BT-0400251-EB	URETHANE HOSE, BLACK	ウレタンホース黒	(0.1)
7		BT-0400251-EB	URETHANE HOSE, BLACK	ウレタンホース黒	(0.1)
8		PJ-0460525-03	HOSE ELBOW	ホースエルボ	(6)
9		TA-1250406-R0	RUBBER PLUG D=12.5 L=4	止め栓 D=12.5 L=4	(1)
10		WP-0510516-SD	WASHER 5.1X7.5X0.5	平座金 5.1 X 7.5 X 0.5	(2)
11		229-07554	PRESSER SPRING REGULATOR ASM.	押え調節ねじナット組	1
12		229-07505	PRESSER SPRING REGULATOR	押え調節ねじ	(1)
13		229-07604	PRESSER SPRING REGULATOR NUT	押え調節ねじナット	(1)
14		B1611-220-000	SPRING	中押えばね	1
15		142-08409	PRESSER GUIDE BAR	中押え案内棒	1
16		B1504-051-000	PRESSER BAR GUIDE BRACKET	押え棒抱き案内	1
17		SS-9091010-SP	SCREW 9/64-40 L=10	六角ボルト 9/64-40 L=10	1
18		G1603-875-000	PRESSER BAR CONNECTION	押え棒抱き	1
19		SS-8660810-TP	SCREW 1/4-40 L=8	止めねじ 1/4-40 L=8	1
20		SS-4121415-SP	SCREW 3/16-28 L=14	なべねじ 3/16-28 L=14	2
21		G1604-875-000	PRESSER BAR	押え棒	1
22		G1606-875-000	PRESSER PLUNGER	押えプランジャ	1
23		G1611-870-000	AIR ADJUSTING	エア継手	1
24		G1605-870-000	PRESSER PLUNGER FITTING PLATE	押えプランジャ取付板	1
25		SM-4051001-SN	SCREW M5	なべ小ねじ M5 X 0.8 L=10	1
26		G1610-870-000	PIPE ADJUSTING	配管継手	1
27		PJ-0460525-03	HOSE ELBOW	ホースエルボ	1
28		SS-9111010-SP	SCREW 11/64-40 L=9.5	六角ボルト 11/64-40 L=9.5	1
29		WS-0451040-KP	SPRING WASHER 4.5X8.5X1	ばね座金 4.5 X 8.5 X 1	1
30		WP-0450826-SC	WASHER 4.5X10X0.8	平座金 4.5 X 10 X 0.8	1
31		CM-3002000-01	ATTENTION SEAL	指怪我注意シール (16)	1
32		SS-6123010-SP	SCREW 3/16-28 L=30.0	平ねじ 3/16-28 L=30	2
33		PJ-3040405-04	UNION	ユニオン	2

7. THREAD TENSION COMPONENTS

糸調子関係

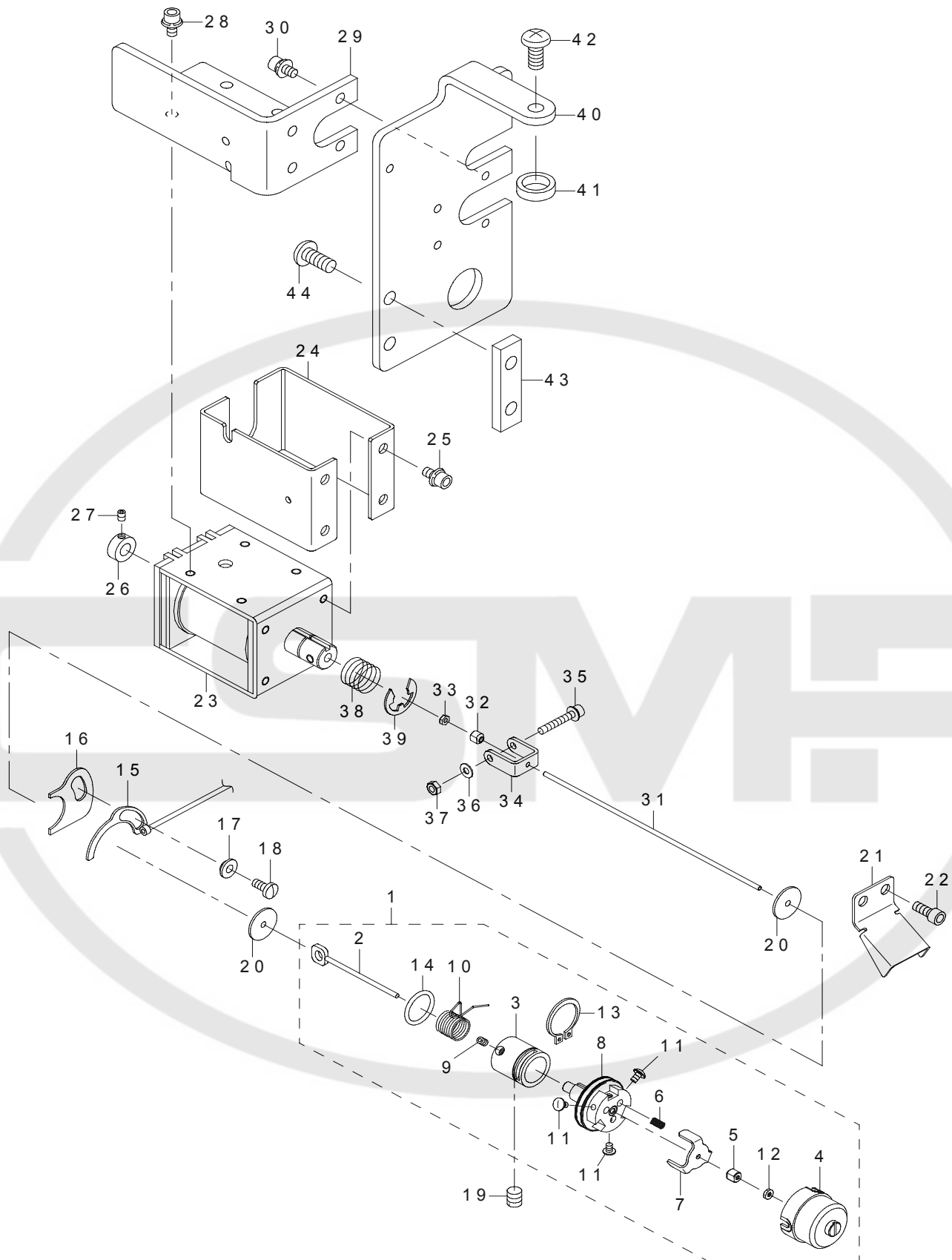

REF.NO	NOTE	PART NO	DESCRIPTION	品名	Qty
1	☆	401-16238	THREAD TENSION ASM.	糸調子(組)	1
2		400-10509	THREAD TENSION SHAFT	糸緩めピン	(1)
3		401-16239	THREAD POST SOCKET	糸調子ポストソケット	(1)
4		400-10511	DISK STOPPER HOLDER CAP	糸調子キャップ	(1)
5		400-10512	THREAD TENSION SHAFT COLLAR	糸緩めピン調節カラー	(1)
6		400-10513	DISK STOPPER SP	糸調子皿戻しばね	(3)
7		400-10514	DISK STOPPER	糸調子皿押え板	(1)
8		400-10515	ASSY THREAD TENSION POST	糸調子棒(組)	(1)
9		400-10478	AT SOL COLLAR SCREW	A T ソレノイドストッパーカラー止めねじ	(1)
10		229-21605	THREAD TAKE-UP SPRING	糸取ばね	(1)
11		400-10521	HOLD CAP SCREW	糸調子キャップ止めねじ	(3)
12		400-10522	SHAFT NUT	糸緩めピン調節カラー止めナット	(1)
13		400-10523	POST BASE C RING	糸調子ストッパー C リング	(1)
14		RO-1331701-00	O-RING	O リング	(1)
15		401-05165	THB SENSOR ASSY	糸切れ検知組	1
16		G2313-870-000	THREAD CUTTING SENSOR PLATE INSULATING PLATE	糸切れ検知板絶縁板	1
17		B2703-210-000	BUSHING	糸切れ検知板ブッシュ	1
18		SS-7090850-SP	SCREW 9/64-40 L=8	丸平ねじ 9/64-40 L=8	1
19		SS-8150760-TP	SCREW 15/64-28 L=7.0	止めねじ 15/64-28 L=7	1
20		401-16240	OIL SEAL RUBBER	油きりゴム	2
21		401-16241	OIL PREUNET PLATE	糸調子軸油防板	1
22		SS-6111052-TP	SCREW	六角穴ボルト	2
23		400-16908	AT SOLENOID	A T ソレノイド	1
24		400-88163	LOWER SOLENOID COVER B	下マニマグネットカバー B	1
25		SL-6040892-TN	SCREW M4 L=8	座金付き六角穴ボルト M4 L=8	4
26		400-10477	AT SOL COLLAR	A T ソレノイドストッパーカラー	1
27		SM-8030412-TP	SCREW	止めねじ M3 L=4	2
28		SL-6040892-TN	SCREW M4 L=8	座金付き六角穴ボルト M4 L=8	4
29		401-16242	SOLENOID PLATE	ソレノイド取付板	1
30		SL-6040892-TN	SCREW M4 L=8	座金付き六角穴ボルト M4 L=8	4
31		401-16243	TENSION SHAFT	糸調子軸	1
32		400-10512	THREAD TENSION SHAFT COLLAR	糸緩めピン調節カラー	1
33		NM-6020001-SC	NUT M2X0.4 TYPE1	六角ナット M2 X 0.4 1種	1
34		400-16911	THREAD TENSION SHAFT HOLDER	糸調子軸ホルダ	1
35		SL-6032092-TN	SCREW M3 L=20	座金付き六角穴ボルト M3 L=20	1
36		WP-0320501-SC	WASHER M3	平座金 M3	1
37		NM-6030001-SC	NUT M3X0.5 TYPE1	六角ナット M3 X 0.5 1種	1
38		400-06625	SPRING	ばね	1
39		RE-0900000-KP	SNAP RING 9	E 形止め輪	1
40		401-16244	AT FITTING PLATE	A T 取付板	1
41		227-98607	SENSING BASE WASHER	膝上げ検知座金	1
42		SS-4151415-SP	SCREW 15/64-28 L=14	なべねじ 15/64-28 L=14	1
43		401-16245	AT FITTING SPACER B	A T 取付スペーサ B	1
44		SS-4151415-SP	SCREW 15/64-28 L=14	なべねじ 15/64-28 L=14	2

8. SHUTTLE DRIVER SHAFT COMPONENTS

下軸関係

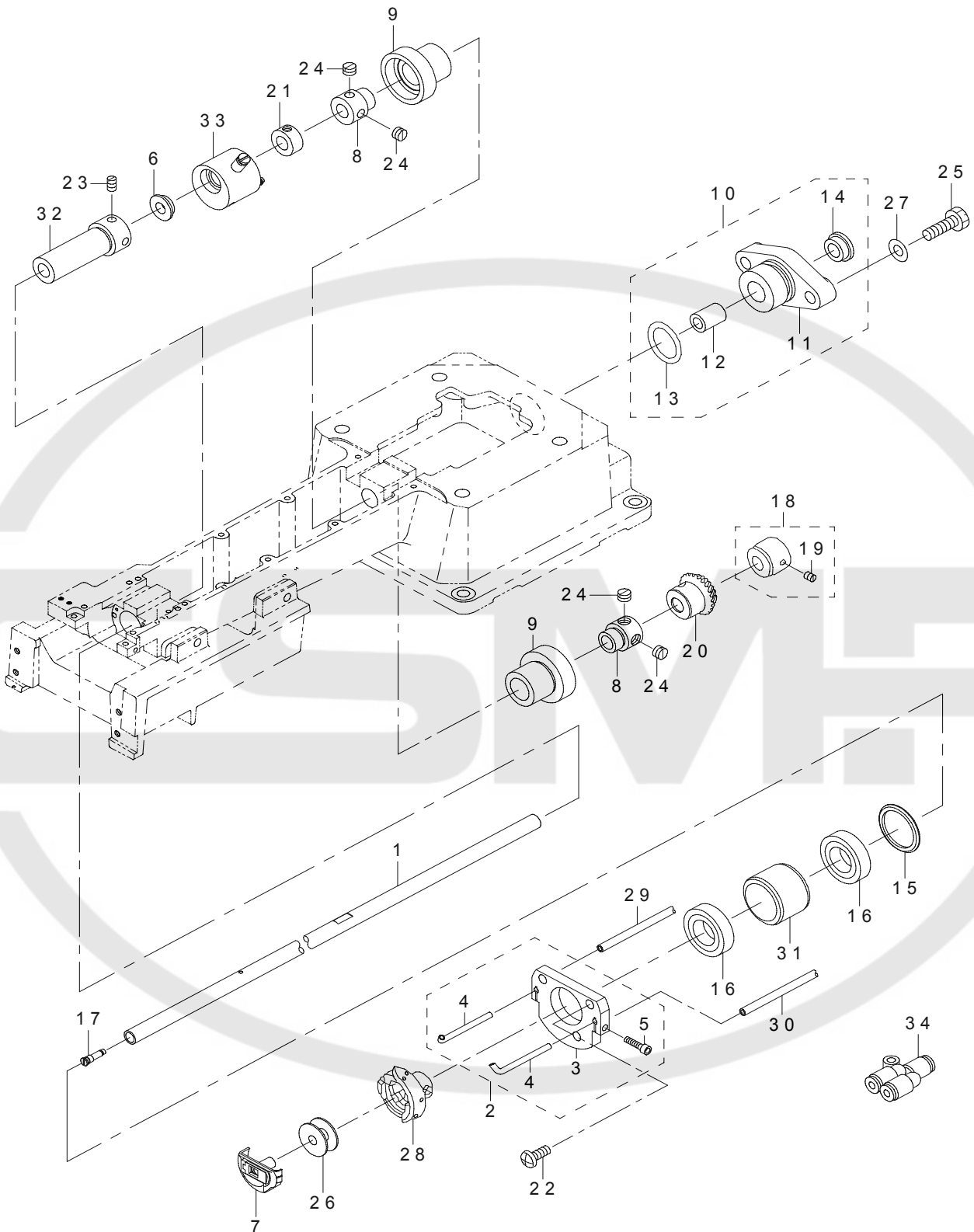

REF.NO	NOTE	PART NO	DESCRIPTION	品名	Qty
1		G1801-875-000	HOOK DRIVING SHAFT	下軸	1
2		G1802-875-0A0	FIXING PLATE ASM.	下軸前軸受け固定板組	1
3		G1802-875-000	FIXING PLATE	下軸前軸受け固定板	(1)
4		G1803-875-000	HOOK DUST REMOVAL PIPE	釜埃除去パイプ	(2)
5		SM-6031202-TP	SCREW M3X0.5 L=12	六角穴ボルト	(2)
6		G1808-870-000	LOWER SHAFT HOUSING BUSH	下軸ハウジングブッシュ	1
7	☆	G1816-875-0A0	BOBBIN CASE ASM.	ボビンケース組	1
8		G1810-870-000	SLEEVE B	スリーブ B	2
9		G1811-870-0A0	LOWER SHAFT HOUSING ASM.	下軸ハウジング結合	2
10		G1813-870-0A0	LOWER SHAFT BLOCK ASM.	下軸ブロック結合	1
11		G1813-870-000	LOWER SHAFT BLOCK	下軸ブロック	(1)
12		119-11203	BUSHING, REAR	上送り軸後メタル	(1)
13		RO-1952401-00	RUBBER RING	O リング	(1)
14		TA-1250406-R0	RUBBER PLUG D=12.5 L=4	止め栓 D = 12.5 L = 4	(1)
15		G1303-870-000	UPPER BEARING SPACER	上ベアリングスペーサ	1
16		G1211-870-000	UPPER SHAFT MIDDLE METAL BEARING	上軸中メタルベアリング	2
17		229-16506	SET SCREW	下軸前止めねじ	1
18		229-50950	CAM COLLAR ASM.	カムカラー (組)	1
19		SS-8110520-TP	SCREW 11/64-40 L= 4.5	止めねじ 11/64-40 L = 4.5	(1)
20		B1308-155-0A0	PINION ASM.	下傘歯車小組	1
21		CS-079073A-SH	THRUST COLLAR ASM.	スラスト受け組	1
22		SS-4121215-SP	SCREW 3/16-28 L=12	なべねじ 3/16-28 L = 12	3
23		SS-8110750-SP	SCREW 11/64-40 L= 6.5	止めねじ 11/64-40 L = 6.5	2
24		SS-8660610-TP	SCREW 1/4-40 L=6	止めねじ 1/4-40 L = 6	4
25		SS-9151910-SN	SCREW 15/64-28 L=19	六角ボルト 15/64-28 L = 19	2
26	☆	G1817-875-000	BOBBIN	ボビン	1
27		WP-0621016-SD	WASHER 6.2X13X1	平座金 6.2 X 13 X 1	2
28	☆	400-72028	HOOK X ASM.	釜 X	1
29		BT-0400251-EB	URETHANE HOSE, BLACK	ウレタンホース黒	0.15
30		BT-0400251-EB	URETHANE HOSE, BLACK	ウレタンホース黒	0.13
31		G1804-870-000	LOWER SHAFT SPACER COLLAR	下軸スペーサカラー	1
32		G1805-870-000	SLEEVE A	スリーブ A	1
33		G1806-870-0B0	LOWER SHAFT OILING HOUSING ASM.	下軸給油ハウジング組	1
34		PJ-3080400-02	QUICK JOINT	ワンタッチ継手	1

9. THREAD TRIMMER MECHANISM COMPONENTS (1)

糸切り関係 (1)

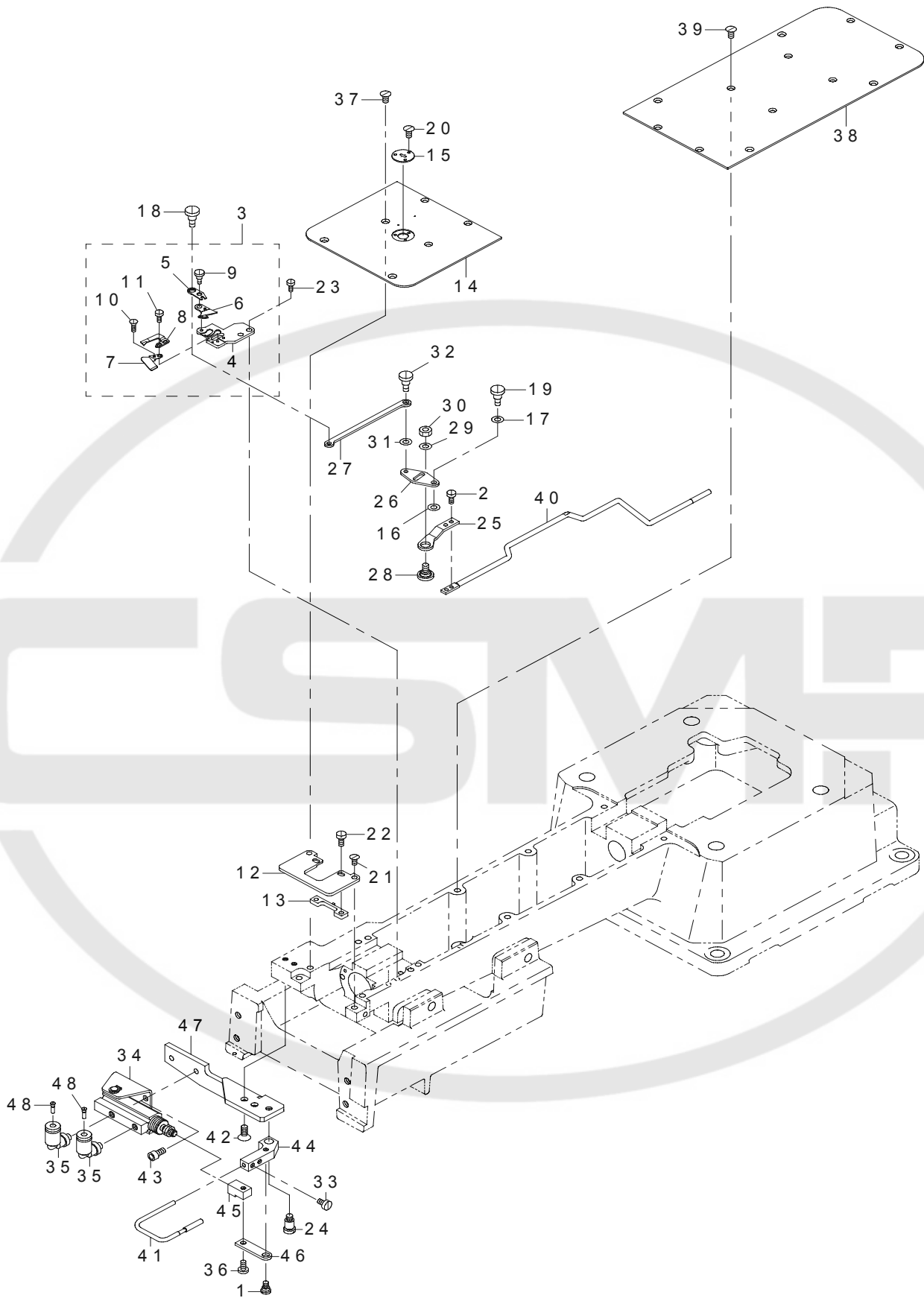

REF.NO	NOTE	PART NO	DESCRIPTION	品名	Qty
1		SD-0500204-TP	HINGE SCREW	段ねじ	1
2		SS-7110710-SP	SCREW 11/64-40 L=7	丸平ねじ 11/64-40 L=7	2
3		G2409-875-0A0	KNIFE INSTALLING BASE ASM.	メス取付台組	1
4		G2409-875-000	KNIFE FITTING BASE	メス取付台	(1)
5		G2410-870-000	MOVING KNIFE ARM	動メスアーム	(1)
6	☆	114-09257	MOVING KNIFE J ASM.	動メス J (組)	(1)
7	☆	114-09802	THREAD TENSION GUIDE	メス糸案内	(1)
8	☆	114-09604	FIX KNIFE	固定メス	(1)
9		SD-0500231-TP	HINGE SCREW	段ねじ D=5 H=2.25	(1)
10		SS-2060210-SP	SCREW 3/32-56 L=2.3	丸皿ねじ 3/32-56 L=2.3	(1)
11		SS-4080620-TP	SCREW 1/8-44 L=6	なべねじ 1/8-44 L=6	(2)
12		G2418-875-000	INSTALLING PLATE	中釜押え取付板	1
13		G2419-875-000	INNER HOOK PRESSER	中釜押え	1
14		G2420-875-000	THROAT PLATE A	針板 A	1
15	#01	G2422-875-000	NEEDLE HOLE GUIDE	針穴ガイド	1
16		112-73505	BRANCH SPACER	ボテンシヨニ又スペーサー	1
17		B2557-280-00A	WASHER FOR DRIVING ARM	横送り腕座金 A	1
18		SD-0600181-TP	HINGE SCREW	段ねじ	1
19		SD-0640391-TP	HINGE SCREW D=6.35 H=3.9	段ねじ D=6.35 H=3.9	1
20		SS-1060210-TP	SCREW 3/32-56 L=2.2	皿ねじ 3/32-56 L=2.2	3
21		SS-1121010-SP	SCREW	皿ねじ	2
22		SS-6110610-TP	SCREW 11/64-40 L=6	平ねじ 11/64-40 L=6	2
23		SS-6121050-SP	SCREW 3/16-28 L=9.5	平ねじ 3/16-28 L=9.5	2
24		SD-0640752-TP	HINGE SCREW D=6.35 H=7.5	段ねじ D=6.35 H=7.5	1
25		G2406-870-000	MOVING KNIFE LINK, B	動メスリンク B	1
26		401-16040	MOVING KNIFE LINK	動メスリンク	1
27		G2408-870-000	MOVING KNIFE LINK, D	動メスリンク D	1
28		229-50000	PICKER LINK PIN	ピッカーリンクピン	1
29		WP-0621016-SH	WASHER	平座金	1
30		NS-6150430-SP	NUT 15/64-28	六角ナット 15/64-28	1
31		B1618-804-000	WASHER	主送り腕座金	1
32		SD-0600403-TP	SHOULDER SCREW D=6 H=4	段ねじ D=6 H=4	1
33		SS-6090670-TP	SCREW 9/64-40 L=6	平ねじ 9/64-40 L=6	2
34		PA-1001013-A0	PIN CYLINDER	ピンシリンダ	1
35		PJ-3040405-04	UNION	ユニオン	2
36		SS-7090710-SP	SCREW 9/64-40 L=6.8	丸平ねじ 9/64-40 L=6.8	1
37		SS-1121010-SP	SCREW	皿ねじ	4
38		G2421-875-000	THROAT PLATE B	針板 B	1
39		SS-1121010-SP	SCREW	皿ねじ	8
40		401-16039	CONNECTING BAR	糸切連結棒	1
41		229-50356	HOOK THREAD PRESSER ASM.	釜糸押え (組)	1
42		SS-2111010-TP	SCREW 11/64-40 L=9.5	丸皿ねじ 11/64-40 L=9.5	2
43		SM-6040802-TP	SCREW M4X0.7 L=8	六角穴ボルト	2
44		G2415-875-000	PICKER HOLDER	ピッカーホルダ	1
45		G2416-875-000	PICKER CYLINDER PIN	ピッカーシリンダピン	1
46		G2417-875-000	PICKER LINK	ピッカーリンク	1
47		401-16246	PICKER BASE	ピッカーベース	1
48		PC-022403E-00	INSERT RING 0.5	インサートリング 0.5	2
		NOTE(注記)	#01....SELECTIVE PARTS	選択部品	

10. THREAD TRIMMER MECHANISM COMPONENTS (2)

糸切り関係 (2)

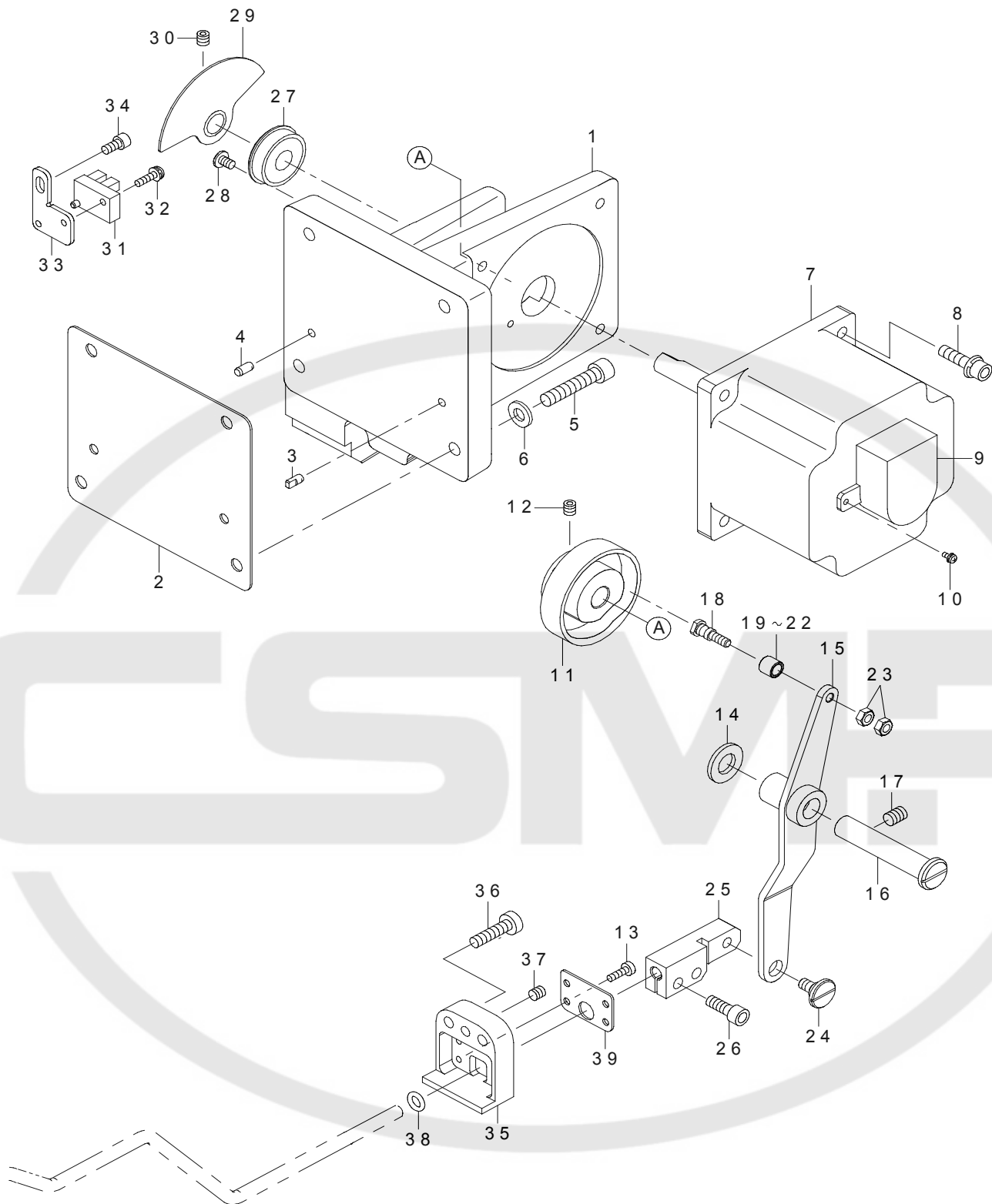

REF.NO	NOTE	PART NO	DESCRIPTION	品名	Qty
1		401-16036	SOLENOID BASE	糸切りソレノイド土台	1
2		401-16037	SOLENOID BASE CUSHION	糸切りソレノイド土台パッキン	1
3		133-01908	DOWEL PIN	ダウエルピン	1
4		133-02500	DOWEL PIN 2	ダウエルピン2	1
5		SM-6063002-TP	SCREW M6 L=30	搬送体軸受け止めねじ	4
6		WP-0641601-SC	WASHER M6	平座金みがき丸 M 6	4
7		400-71944	STEPPING MOTOR	ステッピングモータ	1
8		SL-6052092-TN	SCREW M5 L=20	座金付き六角穴ボルト M 5 L = 2 0	4
9		HD-0027800-00	SENSOR	センサー	1
10		SL-4020591-SC	SCREW M2 L=5	座金付きなべ小ねじ M 2 L = 5	2
11		401-16038	THREAD TRIMMER CAM	糸切りカム	1
12		SM-8050592-TP	SCREW	止めねじ M 5 L = 5 くぼみ先	2
13		SM-6031010-SC	SCREW M3X0.5 L=10	平小ねじ M 3 X 0. 5 L = 1 0	4
14		400-78113	COLLAR	敷き座金	1
15		400-72228	THREAD TRIMMER LINK ASM.	糸切りリンク組	1
16		400-23624	THREAD TRIMMER SHAFT	糸切りリンク軸	1
17		SM-8060812-TP	SCREW M6 L=8	止めねじ M 6 L = 8	2
18		400-40256	CAM ROLLER SHAFT	カムコロ軸	1
19		235-17501	NEEDLE CAM ROLLER A	針振りカムコロ A	1
20		235-17600	NEEDLE CAM ROLLER B	針振りカムコロ B	1
21		235-17709	NEEDLE CAM ROLLER C	針振りカムコロ C	1
22		235-17808	NEEDLE CAM ROLLER D	針振りカムコロ D	1
23		NM-6040001-SP	NUT M4X0.7 TYPE1	六角ナット M 4 X 0. 7 1種	2
24		SD-0800327-TP	SHOULDER SCREW D=8 H=3.2	段ねじ D = 8 H = 3. 2	1
25		401-16041	CONNECTING BAR JOINT	連結ナックル	1
26		SM-6051402-TP	SCREW M5X0.8 L=14	六角穴ボルト M 5 X 0. 8 L = 1 4	2
27		SB-1100024-00	BEARING	ころがり軸受	1
28		SM-6040650-TP	SCREW	平ねじ M 4 L = 6	1
29		401-16042	SENSOR SLIT ASM.	センサースリット (組)	1
30		SM-8050592-TP	SCREW	止めねじ M 5 L = 5 くぼみ先	2
31		HD-0005700-0A	SENSOR	フォトセンサ	1
32		SL-4031291-SC	SCREW M3 L=12	座金付きなべ小ねじ M 3 L = 1 2	1
33		400-10443	SENSOR INSTALLING BASE	押え上げセンサー取付板	1
34		SM-6040802-TP	SCREW M4X0.7 L=8	六角穴ボルト M 4 X 0. 7 L = 8	1
35		401-16247	COUPLING SHAFT OIL BASE	連結棒油切ベース	1
36		SM-6052010-SC	SCREW M5X0.8 L=20	平小ねじ M 5 X 0. 8 L = 2 0	2
37		SM-8050502-TP	SCREW M5 L=5	止めねじ	1
38		RO-0552001-00	O-RING	O リング	1
39		401-16248	OIL SEAL RUBBER PLATE	オイルシールラバープレート	1

11. LUBRICATION COMPONENTS (1)

給油関係 (1)

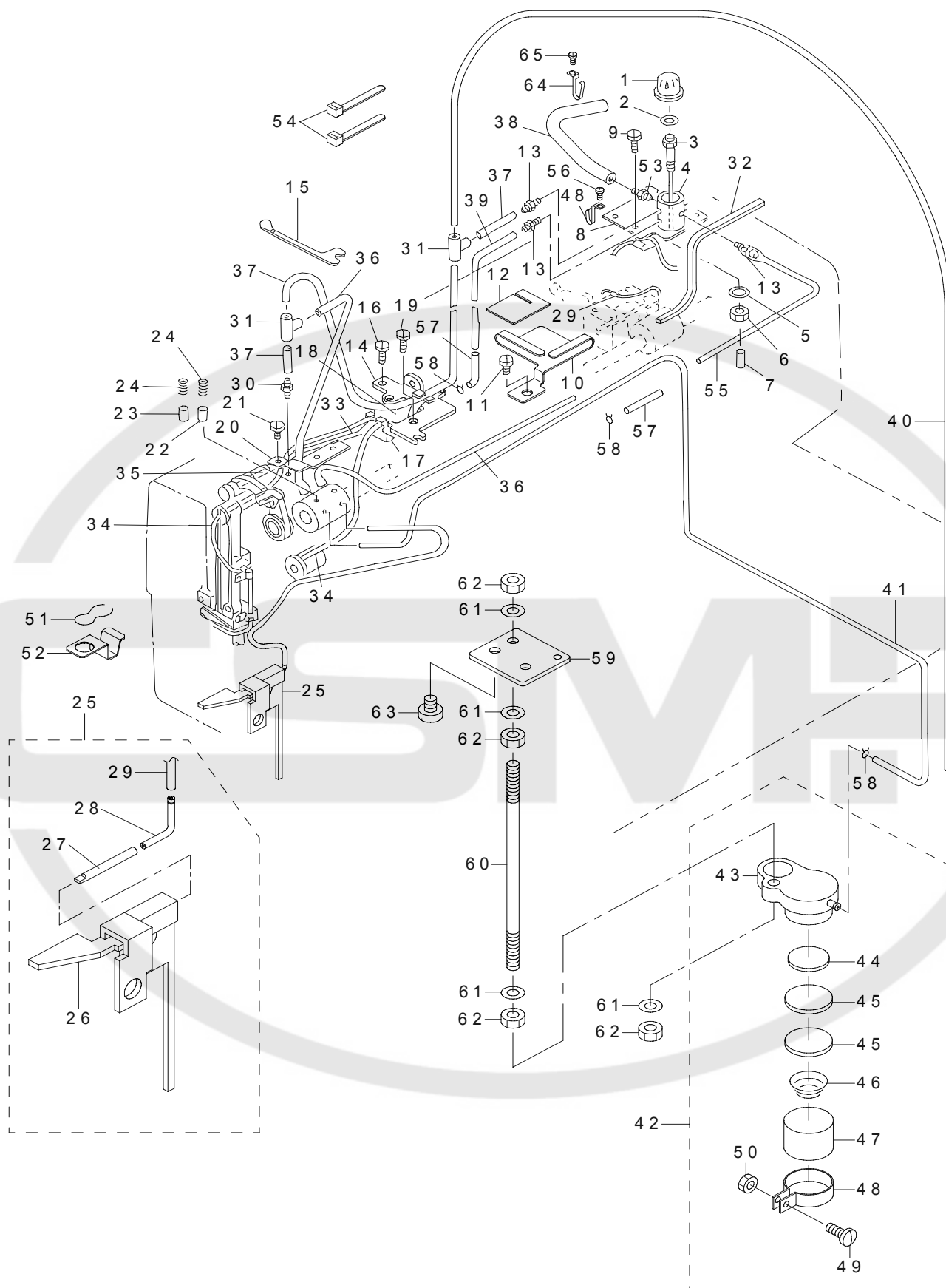

REF.NO	NOTE	PART NO	DESCRIPTION	品名	Qty
1		137-65904	OIL WINDOW	油窓	1
2		RO-0981901-00	RUBBER RING	Oリング	1
3		137-65706	SHAFT SUPPORTER	給油分離軸支え	1
4		137-65805	SHAFT	給油分離軸	1
5		RO-0360802-00	RUBBER RING	Oリング	1
6		NS-6110420-SP	NUT 11/64-40	六角ナット 11/64-40	1
7		TA-0180401-M0	NEEDLE COOLER PLUG CAP	止め栓 D=1.8 X 2.1 L=4.3	1
8		G3531-875-000	FITTING PLATE	給油分離軸取付板	1
9		SS-4120615-SP	SCREW 3/16-28 L=6	なべねじ 3/16-28 L=6	2
10		139-40804	FELT GUIDE B	ウォーム給油フェルト案内B	1
11		SS-4120615-SP	SCREW 3/16-28 L=6	なべねじ 3/16-28 L=6	1
12		G3522-870-000	HOOK FELT	釜フェルト	1
13		SQ-1110402-MZ	CONNECTING SCREW	チューブ連結ねじ	3
14		137-51607	STOPPER PLATE	連動腕ストッパー台	1
15		137-67603	UPPER FACE COVER PACKING	上面カバーパッキン板	1
16		SS-6120940-SP	SCREW 3/16-28 L=9	平ねじ 3/16-28 L=9	2
17		137-66407	OIL TANK B	給油タンク B	1
18		137-66506	OIL TANK B FELT	給油タンク B フェルト	2
19		SS-7110350-SP	SCREW 11/64-40 L=3.5	丸平ねじ 11/64-40 L=3.5	1
20		137-66605	THRUST PLATE	プランジャーばね受け	1
21		SS-7150740-SP	SCREW 15/64-28 L=7	丸平ねじ 15/64-28 L=7	1
22		137-67405	PLUNGER	プランジャ	1
23		B3534-155-000	PLUNGER	プランジャー	1
24		B1214-038-000	PLUNGER SPRING	プランジャー押えばね	2
25		G3517-875-0A0	FACE PLATE OIL FELT ASM.	面部還流フェルト組	1
26		G3517-875-000	FACE PLATE OIL FELT	面部還流フェルト	(1)
27		139-41307	OIL RETURN FELT PIPE	還流フェルトパイプ	(1)
28		137-28506	OIL RETURN FELT CONNEC. PIPE	下軸前メタル給油パイプ	(1)
29		BT-0500300-EG	OIL TUBE	チューブ	(0.2)
30		SQ-1120451-MZ	CONNECTING SCREW	チューブ連結ねじ	1
31		137-65607	OIL CONNEC. ARM	給油連結腕	2
32		B3541-012-000	OIL WICK	還流油芯	1
33		CQ-3030000-00	OIL WICK	油芯	0.8
34		CQ-2020000-00	OIL WICK	油芯	1.4
35		CQ-3000000-F0	OIL FELT	ロッドフェルト	0.04
36		BT-0500300-EG	OIL TUBE	チューブ	0.24
37		BT-0500300-EA	OIL TUBE	ウレタンチューブ	0.24
38		BT-0500300-EA	OIL TUBE	ウレタンチューブ	0.14
39		BT-0500300-EA	OIL TUBE	ウレタンチューブ	0.21
40		BT-0500300-EA	OIL TUBE	ウレタンチューブ	0.65
41		BT-0500300-EA	OIL TUBE	ウレタンチューブ	0.8
42		139-41653	OIL PUMP BASE ASM.	給油台組	1
43		139-41604	OIL PUMP BASE	給油台	(1)
44		B3570-771-000	FILTER	給油台フィルター	(1)
45		137-65201	OIL FILTER	給油フィルタ	(2)
46		B3118-352-000	THREAD TENSION SPRING	糸調子ばね	(1)
47		139-41802	FILTER	給油網	(1)
48		B1850-512-000	BUSHING HOLDER	給油口金具	(1)
49		SS-6090910-SP	SCREW 9/64-40 L=9	平ねじ 9/64-40 L=9	(1)
50		NS-6090310-SP	NUT 9/64-40	六角ナット 9/64-40	(1)
51		229-25101	OIL FELT PRESSER	還流フェルト押え	1
52		G3516-875-000	FACE PLATE OIL FELT PRESSER	面部還流フェルト押え	1
53		SQ-1110451-MZ	CONNECTING SCREW	パイプ連結ねじ	1
54		EA-9500B01-00	CABLE BAND	束線バンド	2
55		BT-0500300-EA	OIL TUBE	ウレタンチューブ	0.1
56		SS-4110515-SP	SCREW 11/64-40 L=5	なべねじ 11/64-40 L=5	1
57		139-40903	OIL WICK A	プラスチック焼結油芯 A	2
58		101-26803	OIL TUBE HOLDER	パイプ止め	3
59		401-16249	OIL BASE FITTING PLATE	オイルベースフィッティングプレート	1
60		401-16250	OIL BASE FITTING SHAFT	オイルベースフィッティングシャフト	1
61		WP-0531000-SC	WASHER 5.3X10X1	平座金 5.3 X 10 X 1	4
62		NM-6050003-SC	NUT M5X0.8	六角ナット M5 X 0.8 3種	4
63		SS-6120620-TP	SCREW	平ねじ	2
64		B3508-220-000	OIL TUBE HOLDER	ビニールパイプ押え	2
65		SS-4120615-SP	SCREW 3/16-28 L=6	なべねじ 3/16-28 L=6	1

12. LUBRICATION COMPONENTS (2)

給油関係 (2)

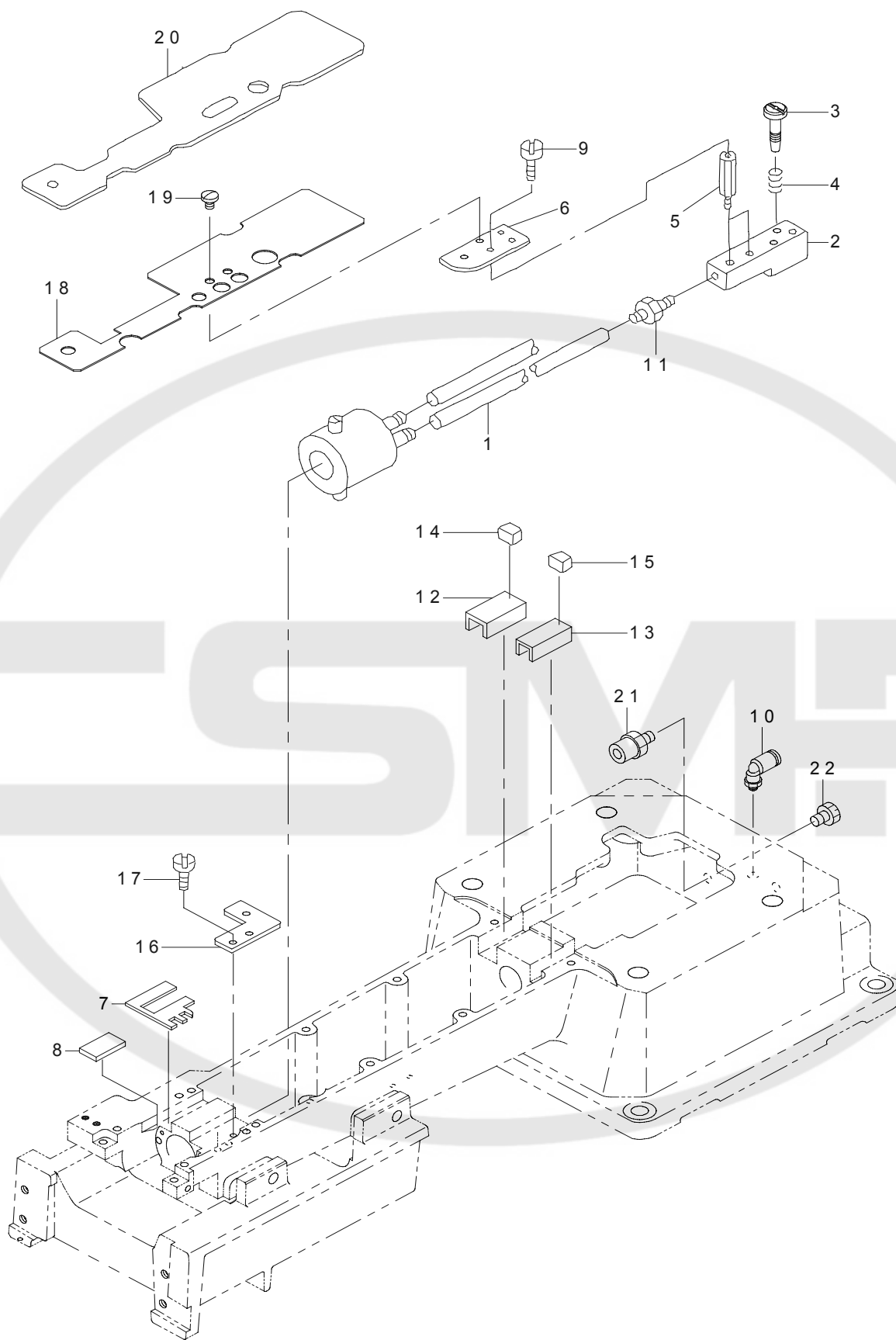

REF.NO	NOTE	PART NO	DESCRIPTION	品名	Qty
1		BT-0500300-EG	OIL TUBE	チューブ	0.09
2		G3515-870-000	HOOK OILING MANIFOLD	釜給油マニホールド	1
3		229-25002	OIL REGULATOR SCREW	下軸前メタル油量調節ねじ	1
4		229-24906	OIL REGULATOR SCREW SPRING	油量調節ねじばね	1
5		G3514-870-000	STUD	スタッド	2
6		G3513-870-000	BYLANE FITTING PLATE	バイリーン取付板	1
7		G3528-875-000	STOPPER RUBBER A	ストップゴム A	1
8		G3529-875-000	STOPPER RUBBER B	ストップゴム B	1
9		SS-6110610-TP	SCREW 11/64-40 L=6	平ねじ 11/64-40 L=6	2
10		PJ-3040405-04	UNION	ユニオン	1
11		SQ-1110401-MZ	CONNECTING SCREW	チューブ連結ねじ	1
12		G3526-870-000	OIL SUPPLY PLATE, A	防油板 A	1
13		G3527-870-000	OIL SUPPLY PLATE, B	防油板 B	1
14		G3528-870-000	PLUG, A	止め栓 A	1
15		G3529-870-000	PLUG, B	止め栓 B	1
16		G3520-870-000	OILING HOUSING FIXING PLATE	給油ハウジング固定板	1
17		SS-7120710-SP	SCREW 3/16-28 L=7	丸平ねじ 3/16-28 L=7	2
18		401-16257	LOWER SHAFT BAFFLE HOLDING PLATE	下軸バッフル受け板	1
19		SS-7110510-SP	SCREW 11/64-40 L=5	丸平ねじ 11/64-40 L=5	2
20		G3519-870-000	LOWER SHAFT BAFFLE	下軸バッフル	1
21		PJ-0320525-03	HOSE NIPPLE	ホースニップル	1
22		PJ-0205000-01	PLUG	プラグ	4



13. MAIN BODY COVER COMPONENTS (1)

装置外装関係 (1)

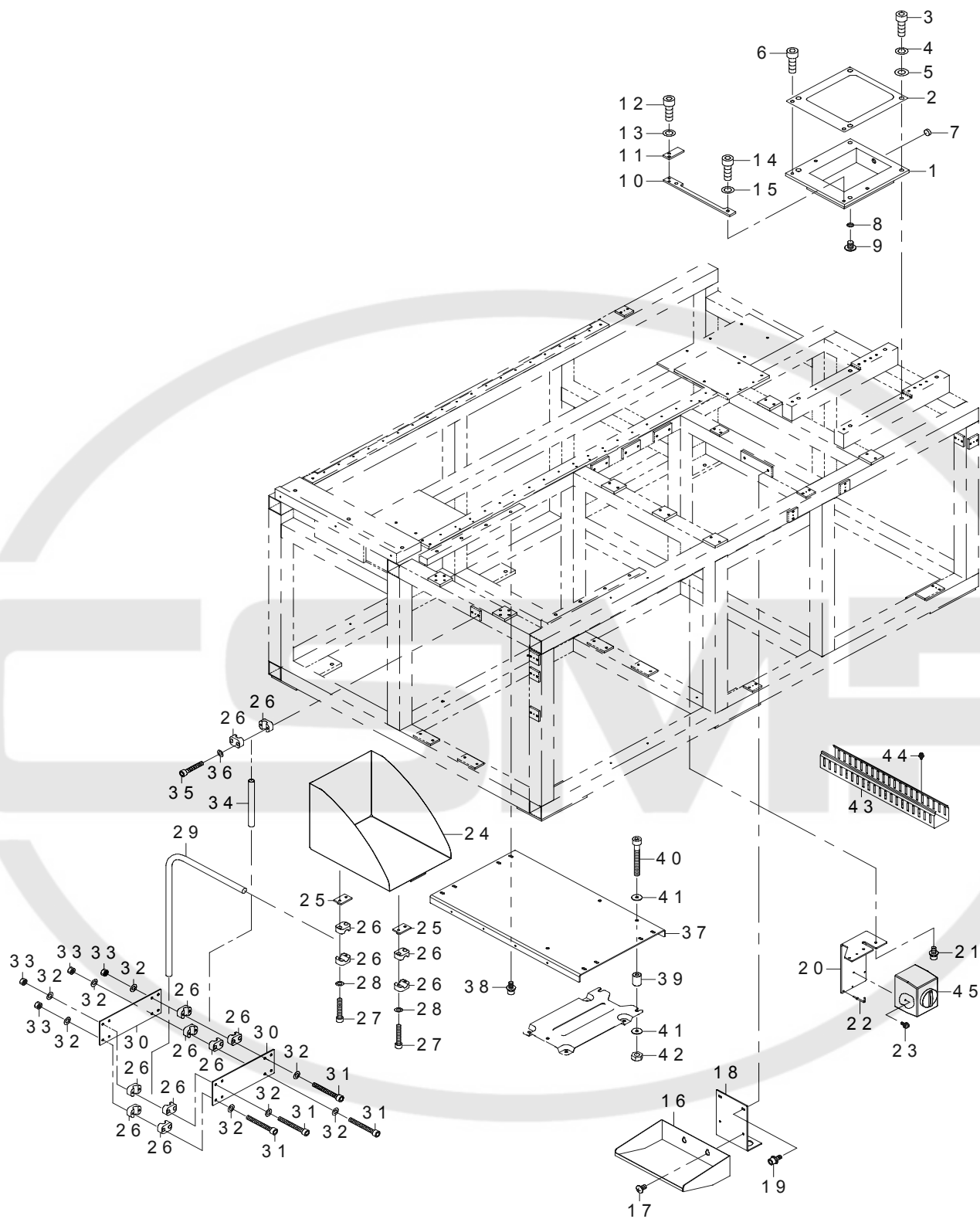

REF.NO	NOTE	PART NO	DESCRIPTION	品名	Qty
1		401-16033	OIL PAN	オイルパン	1
2		401-16548	BACK COVER PACKING	裏面カバーパッキング	1
3		SM-6104502-TP	SCREW M10 L=45	六角穴ボルト M10 L=45	4
4		WS-1020002-KN	SPRING WASHER M10	ばね座金 M10	4
5		WP-1052001-SC	WASHER 10	平座金みがき丸 M10	4
6		SM-6041202-TN	SCREW M4X0.7 L=12	六角穴ボルト M4 X 0.7 L=12	4
7		B1172-581-000-A	CHAMBER OIL SIGHT GAUGE	オイルゲージ	1
8		131-70105	RUBBER RING	Oリング	1
9		SM-0081001-SD	SCREW	トラスねじ M8 L=10	1
10		G8011-870-000	BED STOPPER A	ベットストッパ A	1
11		G8012-870-000	BED STOPPER B	ベットストッパ B	1
12		SM-6061602-TP	SCREW M6 L=16	六角穴ボルト M6 L=16	2
13		WP-0641601-SC	WASHER M6	平座金みがき丸 M6	2
14		SM-6062502-TN	SCREW	六角穴ボルト	2
15		WP-0641601-SC	WASHER M6	平座金みがき丸 M6	2
16		G8113-875-000	OIL RESERVOIR	油受け	1
17		SM-0050801-SC	SCREW	トラスねじ M5 L=8	2
18		401-16214	OIL PAN INSTALLING PLATE	オイルパン取付板	1
19		SL-6061492-TN	SCREW M6 L=14	座金付き六角穴ボルト M6 L=14	2
20		401-16172	MAIN SW BRACKET	メイン SW ブラケット	1
21		SL-6061492-TN	SCREW M6 L=14	座金付き六角穴ボルト M6 L=14	2
22		G5026-162-000	HOOK	エアガンフック	1
23		SL-4041081-SC	SCREW M4 L=10	座金付きなべ小ねじ M4 L=10	2
24		401-16219	POCKET PUTTING STAND	ポケット置き台	1
25		G7525-870-000	PIPE CLAMP LOWER PLATE	パイプクランプ下板	2
26		G7524-870-000	PIPE CLAMP MAIN BODY	パイプクランプ本体	14
27		SM-6063502-TN	HEXAGONAL-HOLE BOLT M6 L=35	六角穴ボルト M6 L=35	4
28		WP-0641600-SC	WASHEW 6.4X12.5X1.6	平座金	4
29		G7515-870-000	GARMENT PRESSER HOLDER PIPE	身頃押え受けパイプ	1
30		G8018-875-000	POCKET PUT BASE SUPPORT PLATE	ポケット置き台支持板	2
31		SM-6065002-TP	SCREW M6 L=50	六角穴ボルト M6 L=50	8
32		WP-0641601-SC	WASHER M6	平座金みがき丸 M6	16
33		NM-6060001-SC	NUT M6X1 TYPE1	六角ナット M6 X 1 1種	8
34		G7521-870-000	GARMENT CLEARING ARM STOPPER	身頃払い腕ストッパ	1
35		SM-6063502-TN	HEXAGONAL-HOLE BOLT M6 L=35	六角穴ボルト M6 L=35	2
36		WP-0641600-SC	WASHEW 6.4X12.5X1.6	平座金	2
37		401-16220	CONTROLL BOX PLATE	コントロールボックスプレート	1
38		SL-6061492-TN	SCREW M6 L=14	座金付き六角穴ボルト M6 L=14	8
39		400-93183	BOX SPACER	ボックスベース	3
40		SM-6086002-TN	SCREW	ねじ	3
41		WP-0852086-SC	WASHER M8	平座金	6
42		NM-6080001-SC	NUT M8X1.25 TYPE1	六角ナット M8 X 1.25 1種	2
43		HX-0001300-0C	CABLE DUCT	ケーブルダクト	1
44		HX-0041200-00	SCREW RIVET	基板パーツ	6
45		HA-0058200-00	SWITCH	スイッチ	1

14. MAIN BODY COVER COMPONENTS (2)

装置外装関係 (2)

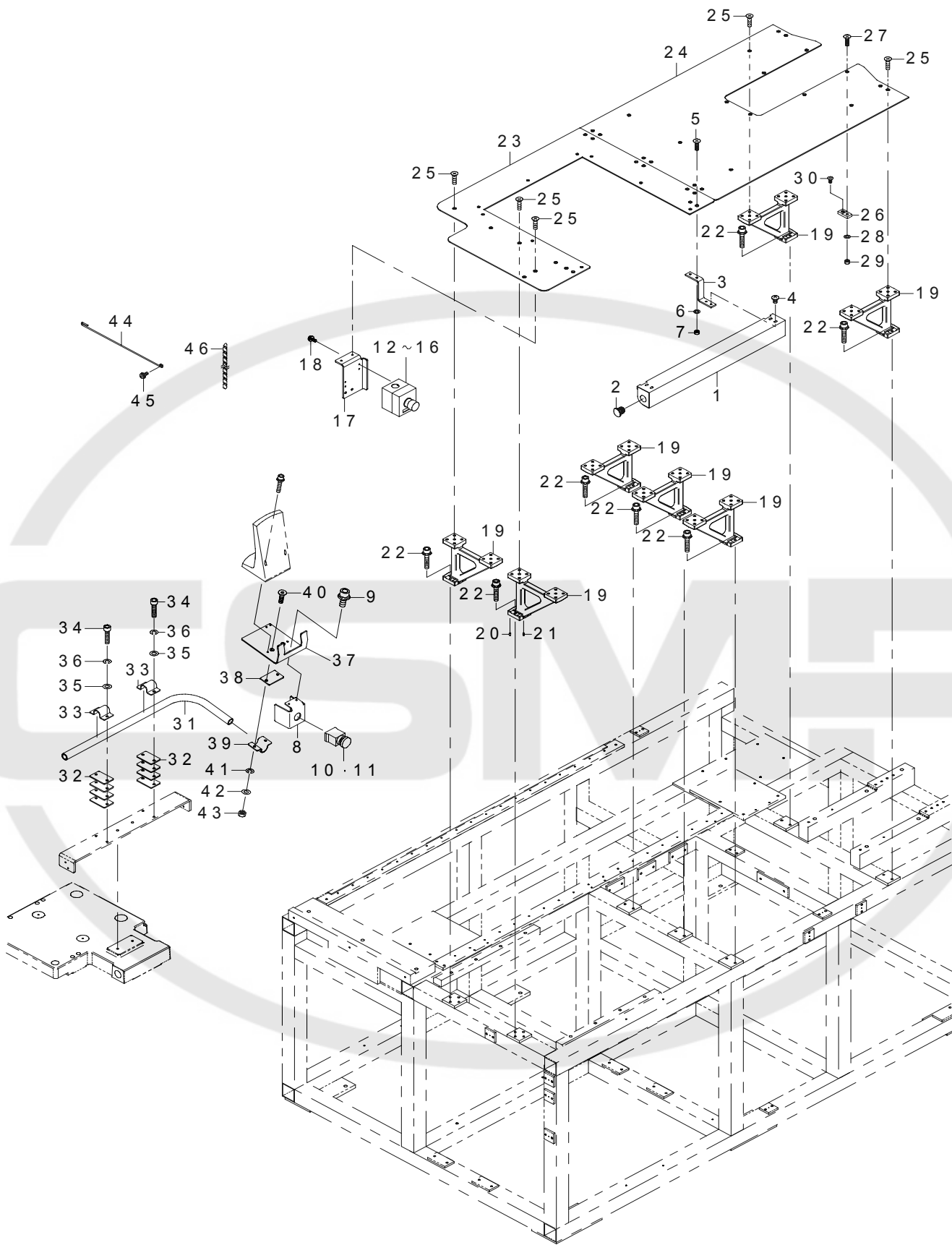

REF.NO	NOTE	PART NO	DESCRIPTION	品名	Qty
1		G8013-875-000	START SW FITTING PLATE	スタート SW 取付板	1
2		HA-0042900-00	SWITCH	スイッチ (緑)	2
3		G8014-875-000	START SW FIXING PLATE	スタート SW 固定板	2
4		SM-0050801-SC	SCREW	トラスねじ M5 L=8	4
5		SM-1051601-SC	SCREW M5X0.8 L=16	皿小ねじ M5 X 0.8 L=16	4
6		WP-0531001-SC	WASHER M5	平座金みがき丸 M5	4
7		NM-6050001-SC	NUT M5X0.8 TYPE1	六角ナット M5 X 0.8 1種	4
8		401-16217	TEMPORARY STOP BRACKET	一時停止ブラケット	1
9		SL-6041092-TN	SCREW M4 L=10	座金付き六角穴ボルト M4 L=10	2
10		HA-0000600-0C	SWITCH	スイッチ	1
11		HA-0042900-10	SWITCH	スイッチカバー	1
12		HA-0062800-00	SWITCH	スイッチ	1
13		HA-0062800-10	SWITCH	スイッチ	1
14		HA-0062800-20	SWITCH	スイッチ	1
15		HA-0062800-30	SWITCH	スイッチ	1
16		400-91335	OFF SW BOX GND PLATE	非常停止 SW ボックス GND 板	1
17		401-16218	EMERGENCY STOP SW BRACKET	非常停止 SW ブラケット	1
18		SL-4041091-SC	SCREW M4 L=10	座金付きなべ小ねじ M4 L=10	2
19		401-15898	TABLE SUPPORT	テーブルサポート	7
20		133-02500	DOWEL PIN 2	ダウエルピン2	2
21		133-01908	DOWEL PIN	ダウエルピン	2
22		SL-6063092-TN	SCREW M6 L=30	座金付き六角穴ボルト M6 L=30	14
23		401-16175	TABLE A	テーブル A	1
24		401-16176	TABLE B	テーブル B	1
25		SM-1051201-SC	SCREW M5X0.8 L=12	皿小ねじ M5 X 0.8 L=12	27
26		G8010-875-000	THROAT PLATE FIXING PLATE	針板固定板	6
27		SM-1051601-SC	SCREW M5X0.8 L=16	皿小ねじ M5 X 0.8 L=16	6
28		WP-0531001-SC	WASHER M5	平座金みがき丸 M5	6
29		NM-6050001-SC	NUT M5X0.8 TYPE1	六角ナット M5 X 0.8 1種	6
30		SM-1040801-SP	SCREW M4X0.7 L=8	皿小ねじ M4 X 0.7 L=8	6
31		401-16215	OPERATION PANEL PIPE	操作パネル支柱	1
32		G1016-192-000	CLAMP BOTTOM PLATE	サドル底板	8
33		G1015-192-000	CLAMP	サドル	2
34		SM-6062502-TN	SCREW	六角穴ボルト	4
35		WP-0641601-SC	WASHER M6	平座金みがき丸 M6	4
36		WS-0610002-KN	SPRING WASHER M6	ばね座金 M6	4
37		401-16216	PANEL PLATE	パネル板	1
38		G1016-192-000	CLAMP BOTTOM PLATE	サドル底板	1
39		G1015-192-000	CLAMP	サドル	1
40		SM-1062052-TP	SCREW M6 L=20	六角穴ボルト M6 L=20	2
41		WS-0610002-KN	SPRING WASHER M6	ばね座金 M6	2
42		WP-0641601-SC	WASHER M6	平座金みがき丸 M6	2
43		NM-6060001-SC	NUT M6X1 TYPE1	六角ナット M6 X 1 1種	2
44		401-05167	PANEL ROD	パネル支え棒	1
45		SL-4041081-SC	SCREW M4 L=10	座金付きなべ小ねじ M4 L=10	2
46		G5454-161-000	SPIRAL TUBE	スパイラルチューブ	0.2

15. FRAME COVER COMPONENTS

外装カバー関係

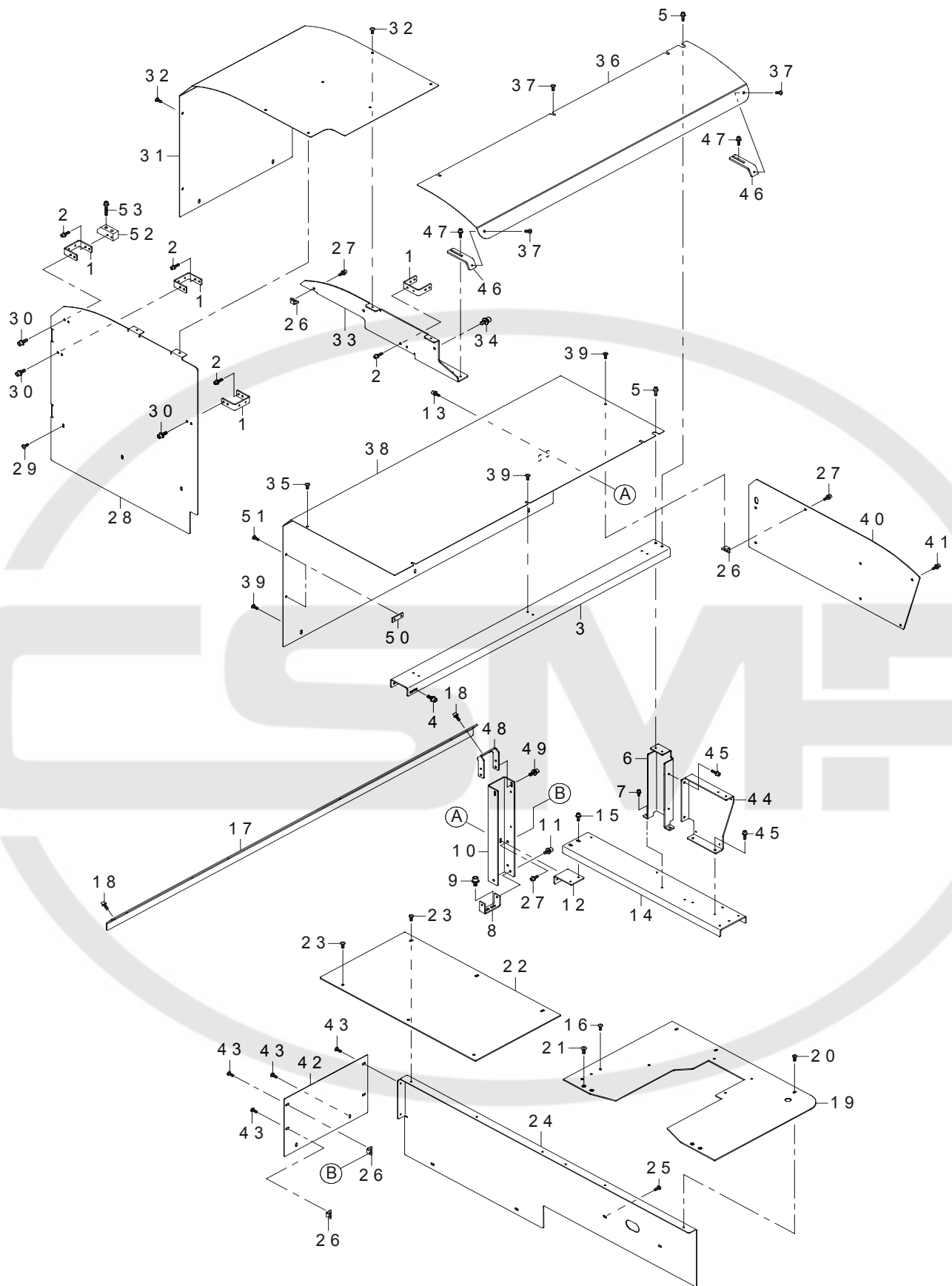

REF.NO	NOTE	PART NO	DESCRIPTION	品名	Qty
1		401-16401	COVER STAY E	カバーステイ E	4
2		SL-6041492-TN	SCREW M4 L=14	座金付き六角穴ボルト M 4 L = 1 4	8
3		401-16402	COVER STAY A	カバーステイ A	1
4		SL-6051492-TN	SCREW M5 L=14	座金付き六角穴ボルト M 5 L = 1 4	4
5		SL-6041492-TN	SCREW M4 L=14	座金付き六角穴ボルト M 4 L = 1 4	2
6		401-16403	COVER STAY D	カバーステイ D	1
7		SL-6051492-TN	SCREW M5 L=14	座金付き六角穴ボルト M 5 L = 1 4	2
8		401-16404	TABLE SUPPORT B	テーブルサポート B	1
9		SL-6061292-TN	SCREW M6 L=12	座金付き六角穴ボルト M 6 L = 1 2	2
10		401-16405	COVER STAY B	カバーステイ B	1
11		SL-6051292-TN	SCREW M5 L=12	座金付き六角穴ボルト M 5 L = 1 2	2
12		401-16406	COVER STAY C SUPPORT PLATE	カバーステイ C サポートプレート	1
13		SL-6041292-TN	SCREW M4 L=12	座金付き六角穴ボルト M 4 L = 1 2	2
14		401-16407	COVER STAY C	カバーステイ C	1
15		SL-6041292-TN	SCREW M4 L=12	座金付き六角穴ボルト M 4 L = 1 2	2
16		SM-0041001-SC	SCREW M4 L=10	トラスねじ M 4 L = 1 0	3
17		401-16408	COVER STAY	カバーステイ	1
18		SL-6041292-TN	SCREW M4 L=12	座金付き六角穴ボルト M 4 L = 1 2	3
19		401-16177	COVER SFR	カバー SFR	1
20		SM-0041001-SC	SCREW M4 L=10	トラスねじ M 4 L = 1 0	3
21		SM-1051201-SC	SCREW M5X0.8 L=12	皿小ねじ M 5 X 0. 8 L = 1 2	4
22		401-16409	COVER RIGHT	カバー右	1
23		SM-0041001-SC	SCREW M4 L=10	トラスねじ M 4 L = 1 0	6
24		401-16410	COVER RIGHT A	カバー右 A	1
25		SM-0041001-SC	SCREW M4 L=10	トラスねじ M 4 L = 1 0	4
26		400-75985	COVER ANGLE	カバー支え	4
27		SL-6041292-TN	SCREW M4 L=12	座金付き六角穴ボルト M 4 L = 1 2	4
28		401-16411	SIDE COVER LEFT LARGE	サイドカバー左 (大)	1
29		SM-0041001-SC	SCREW M4 L=10	トラスねじ M 4 L = 1 0	3
30		SL-6051492-TN	SCREW M5 L=14	座金付き六角穴ボルト M 5 L = 1 4	6
31		401-16412	COVER LEFT	カバー左	1
32		SM-0041001-SC	SCREW M4 L=10	トラスねじ M 4 L = 1 0	12
33		401-16413	SIDE COVER LEFT SMALL	サイドカバー左 (小)	1
34		SL-6061492-TN	SCREW M6 L=14	座金付き六角穴ボルト M 6 L = 1 4	2
35		SM-0041001-SC	SCREW M4 L=10	トラスねじ M 4 L = 1 0	1
36		401-19074	FRONT COVER	フロントカバー	1
37		SM-0041001-SC	SCREW M4 L=10	トラスねじ M 4 L = 1 0	5
38		401-16415	TOP COVER	トップカバー	1
39		SM-0041001-SC	SCREW M4 L=10	トラスねじ M 4 L = 1 0	11
40		401-16416	RIGHT COVER	右カバー	1
41		SM-0041001-SC	SCREW M4 L=10	トラスねじ M 4 L = 1 0	7
42		401-16417	REAR COVER	リアカバー	1
43		SM-0041001-SC	SCREW M4 L=10	トラスねじ M 4 L = 1 0	6
44		401-16418	COVER STAY F	カバーステイ F	1
45		SL-6041492-TN	SCREW M4 L=14	座金付き六角穴ボルト M 4 L = 1 4	4
46		401-16419	COVER STAY H	カバーステイ H	2
47		SL-6041492-TN	SCREW M4 L=14	座金付き六角穴ボルト M 4 L = 1 4	4
48		401-16420	COVER STAY G	カバーステイ G	1
49		SL-6051492-TN	SCREW M5 L=14	座金付き六角穴ボルト M 5 L = 1 4	2
50		401-16421	COVER STAY K	カバーステイ K	2
51		SM-0041001-SC	SCREW M4 L=10	トラスねじ M 4 L = 1 0	4
52		401-16422	COVER STAY BASE	カバーステイベース	1
53		SL-6064092-TN	SCREW M6 L=40	座金付き六角穴ボルト M 6 L = 4 0	2

16. MAIN BODY FRAME COMPONENTS

フレーム関係

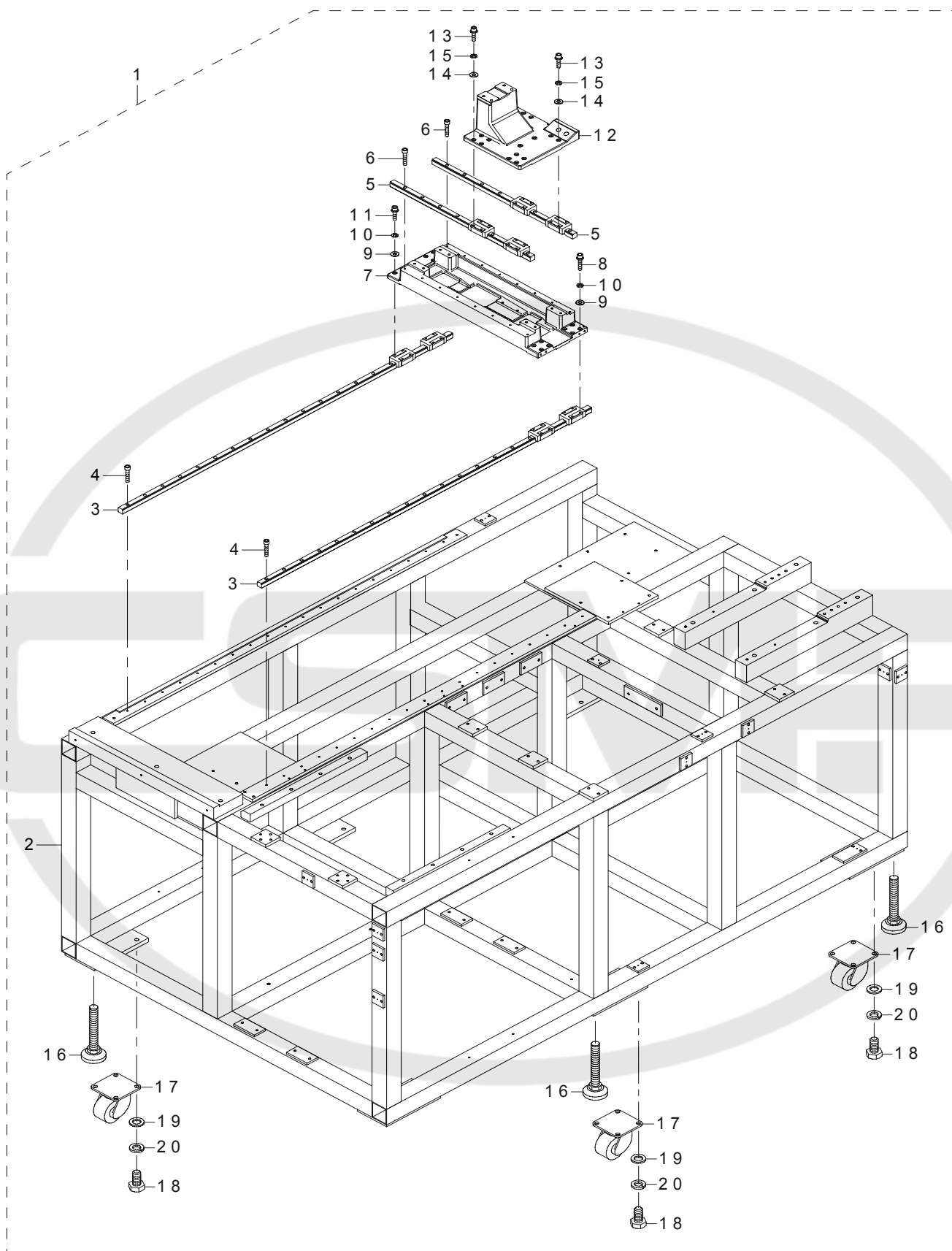

REF.NO	NOTE	PART NO	DESCRIPTION	品名	Qty
1		401-16044	ASSY FRAME	フレーム組	1
2		401-15899	FRAME	フレーム	(1)
3		401-16045	X-LM GUIDE	X - LM ガイド	(2)
4		SM-6042002-TP	SCREW M4X0.7 L=20	六角穴ボルト M 4 X 0. 7 L = 2 0	(38)
5		401-16046	Y-LM GUIDE	Y - LM ガイド	(2)
6		SM-6042002-TP	SCREW M4X0.7 L=20	六角穴ボルト M 4 X 0. 7 L = 2 0	(16)
7		401-16047	X FEED BASE	X 移動ベース	(1)
8		SM-6042002-TP	SCREW M4X0.7 L=20	六角穴ボルト M 4 X 0. 7 L = 2 0	(8)
9		WP-0450801-SD	WASHER 4.5X10X0.8	平座金 4. 5 X 1 0 X 0. 8	(16)
10		WS-0410002-KP	SPRING WASHER	ばね座金 M 4	(16)
11		SM-6041602-TP	SCREW M4X0.7 L=16	六角穴ボルト M 4 X 0. 7 L = 1 6	(8)
12		401-16048	Y FEED BASE A	Y 移動ベース A	(1)
13		SM-6041602-TP	SCREW M4X0.7 L=16	六角穴ボルト M 4 X 0. 7 L = 1 6	(16)
14		WP-0450801-SD	WASHER 4.5X10X0.8	平座金 4. 5 X 1 0 X 0. 8	(16)
15		WS-0410002-KP	SPRING WASHER	ばね座金 M 4	(16)
16		G5030-171-000	ADJUSTING BOLT	アジャスタ	(6)
17		G5006-870-000	CASTER	キャスター	(6)
18		SM-9102003-SB	SCREW M10 L=20	六角ボルト M 1 0 L = 2 0	(24)
19		WP-1052000-SC	WASHER 10.5X18X2	平座金 1 0. 5 X 1 8 X 2	(24)
20		WS-1020002-KN	SPRING WASHER M10	ばね座金 M 1 0	(24)

CSMP

17. X-Y DRIVER UNIT (1)

X - Y 駆動機構 (1)

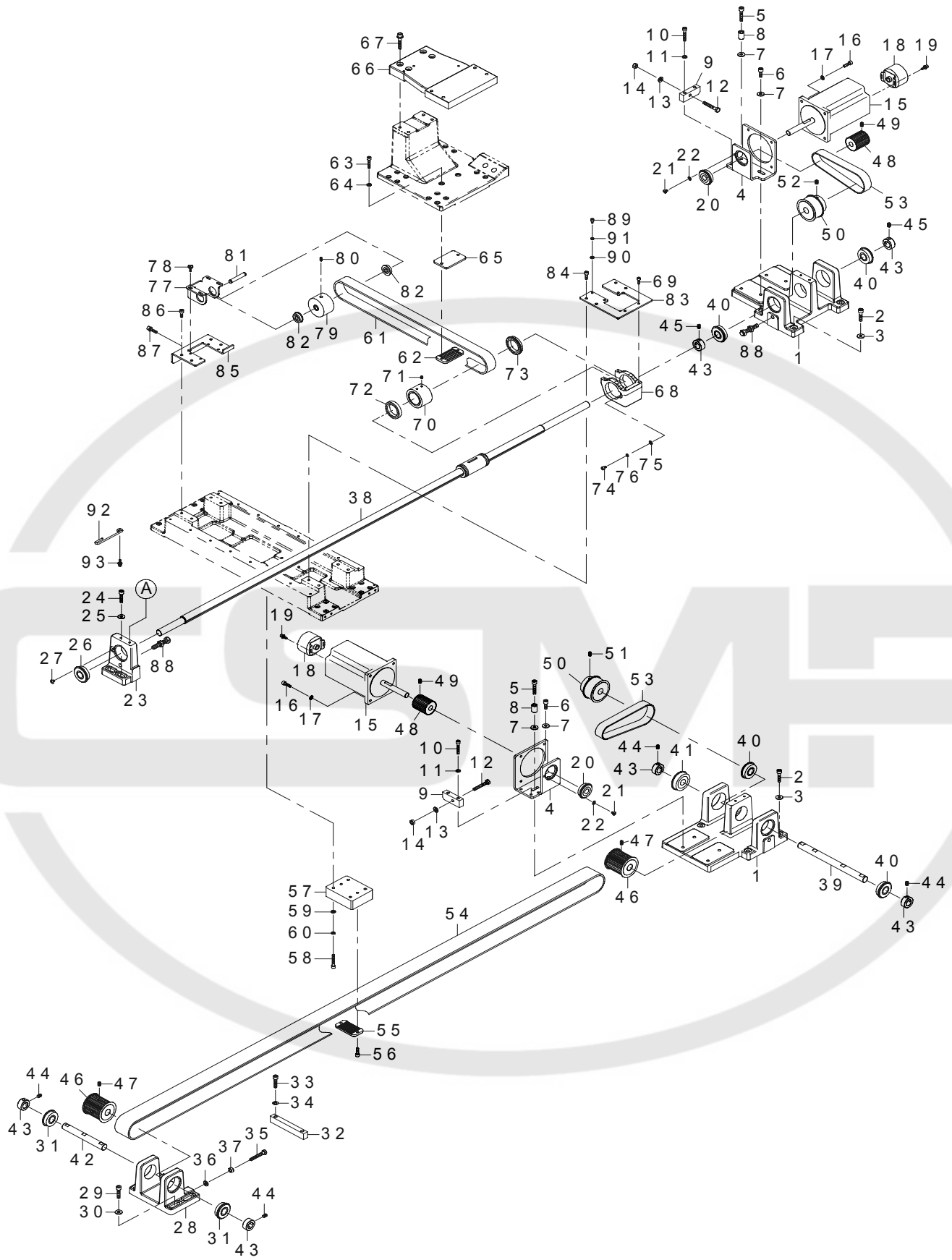

REF.NO	NOTE	PART NO	DESCRIPTION	品名	Qty
1		401-16049	BEARING BASE	ベアリング土台	2
2		SM-6062502-TP	SCREW M6 L=25	六角穴ボルト M6 L=25	8
3		WP-0611626-SP	WASHER 15X6X1.6	平座金	8
4		401-16050	MOTOR BASE	モータ土台	2
5		SM-6063002-TP	SCREW M6 L=30	搬送体軸受止めねじ	2
6		SM-6061602-TP	SCREW M6 L=16	六角穴ボルト M6 L=16	2
7		WP-0611626-SP	WASHER 15X6X1.6	平座金	4
8		GAC-01002A00	COLLAR	ソレノイド取付台座金	2
9		401-16051	MOTOR TENSION PLATE	モータ張力板	2
10		SM-6053002-TP	SCREW M5X0.8 L=30	六角穴ボルト M5X0.8 L=30	4
11		WP-0531000-SD	WASHER M5	平座金小形丸 M5	4
12		SM-9064053-SE	SCREW	六角ボルト	2
13		WP-0641601-SC	WASHER M6	平座金みがき丸 M6	2
14		NM-6060001-SC	NUT M6X1 TYPE1	六角ナット M6X1 1種	2
15		401-05099	STEPPING MOTOR	ステッピングモータ	2
16		SM-6051602-TP	SCREW M5X0.8 L=16	六角穴ボルト M5X0.8 L=16	8
17		WP-0531001-SC	WASHER M5	平座金みがき丸 M5	8
18		401-05098	ENCODER ASSY	エンコーダ組	2
19		SL-4030891-SC	SCREW M3 L=8	座金付きなべ小ねじ M3 L=8	4
20		SB-1120001-00	BEARING	ころがり軸受	2
21		SM-6040650-TP	SCREW	平ねじ M4 L=6	2
22		WP-0430801-SC	WASHER M4	平座金 M4	2
23		401-16053	SPLINE SHAFT BASE	スプライン軸土台	1
24		SM-6062502-TP	SCREW M6 L=25	六角穴ボルト M6 L=25	2
25		WP-0611626-SP	WASHER 15X6X1.6	平座金	2
26		B1802-180-000	BUSHING	駆動軸前メタル	1
27		SM-0040801-SC	SCREW M4X8	トラスねじ M4X8	1
28		401-16054	X PULLEY BASE	X 従動プーリ土台	1
29		SM-6062502-TP	SCREW M6 L=25	六角穴ボルト M6 L=25	4
30		WP-0611626-SP	WASHER 15X6X1.6	平座金	4
31		B1802-180-000	BUSHING	駆動軸前メタル	2
32		401-16055	STOPPER PLATE	X ベルト張力板	1
33		SM-6062502-TP	SCREW M6 L=25	六角穴ボルト M6 L=25	2
34		WP-0641601-SC	WASHER M6	平座金みがき丸 M6	2
35		SM-9064053-SE	SCREW	六角ボルト	2
36		WP-0641601-SC	WASHER M6	平座金みがき丸 M6	2
37		NM-6060001-SC	NUT M6X1 TYPE1	六角ナット M6X1 1種	2
38		401-16056	Y SPLINE SHAFT	Y スプライン軸	1
39		401-16057	X DRIVE SHAFT	X 駆動軸	1
40		B1802-180-000	BUSHING	駆動軸前メタル	4
41		G1216-870-000	UPPER SHAFT REAR BEARING	上軸後ベアリング	1
42		401-16058	X DRIVEN SHAFT	X 従動軸	1
43		CS-1501171-TP	THRUST COLLAR D=15 W=11	スラスト受 D=15 W=11	6
44		SM-8060812-TP	SCREW M6 L=8	止めねじ M6 L=8	8
45		SM-8060802-TP	SCREW M6 L=8	止めねじ M6 L=8	4
46		401-16059	X DRIVE SPROCKET	X 駆動スプロケット	2
47		SM-8060812-TP	SCREW M6 L=8	止めねじ M6 L=8	4
48		401-16060	MOTOR PULLEY	モータプーリ	2
49		SM-8060802-TP	SCREW M6 L=8	止めねじ M6 L=8	4
50		401-16061	DECELERATION PULLEY	減速プーリ	2
51		SM-8060812-TP	SCREW M6 L=8	止めねじ M6 L=8	2
52		SM-8060802-TP	SCREW M6 L=8	止めねじ M6 L=8	2
53		E2314-715-000	TIMING BELT YA	タイミングベルト (YA)	2
54		401-16062	X TIMING BELT	X 駆動ベルト	1
55		401-16063	BELT RECEIVER	ベルト押え	1
56		SM-6051602-TP	SCREW M5X0.8 L=16	六角穴ボルト M5X0.8 L=16	2
57		401-16064	X BELT PRESSER FIX PLATE	X 駆動ベルト押え取付板	1
58		SM-6053002-TP	SCREW M5X0.8 L=30	六角穴ボルト M5X0.8 L=30	4
59		WP-0531001-SC	WASHER M5	平座金みがき丸 M5	4
60		WS-0510002-KN	SPRING WASHER M5	ばね座金 M5	4
61		401-16065	Y TIMING BELT	Y 駆動ベルト	1
62		400-72166	BELT RECEIVER	ベルト押え	1
63		SM-6052502-TP	SCREW M5X25	六角穴ボルト M5X25	2
64		WP-0531000-SD	WASHER M5	平座金小形丸 M5	2
65		401-16066	Y BELT PRESSER FIX PLATE	Y 駆動ベルト押え取付板	1
66		401-16067	Y FEED BASE B	Y 移動ベース B	1
67		SL-6063592-TN	SCREW M6 L=35	座金付き六角穴ボルト M6 L=35	4
68		B2504-221-D00	X DRIVE BRACKET	X 駆動ブラケット	1
69		SM-6041202-TP	SCREW M4X0.7 L=12	六角穴ボルト M4X0.7 L=12	4
70		401-16068	Y DRIVE SPROCKET	Y 駆動スプロケット	1
71		SM-8050412-TP	SCREW M5 L=4	止めねじ M5 L=4	2
72		SB-1300002-00	BEARING	ころがり軸受	1
73		SB-1300003-00	BEARING	ころがり軸受	1
74		SM-6040602-TP	SCREW M4X0.7 L=6	六角穴ボルト M4X0.7 L=6	1
75		WP-0430801-SC	WASHER M4	平座金 M4	1
76		WS-0410002-KN	SPRING WASHER M4	ばね座金 M4	1
77		B2505-221-D00	DRIVEN BRACKET	従動ブラケット	1
78		SM-6041150-TP	SCREW	平ねじ M4 L=11	4
79		401-16069	Y DRIVEN SPROCKET	Y 従動スプロケット	1
80		SM-8050812-TP	SCREW M5X8	止めねじ M5X8	1
81		226-87701	SPRING SHAFT	変換ばね軸	1
82		SB-1080005-00	BEARING	ころがり軸受	2
83		401-16070	Y DRIVE BRACKET BASE	Y 駆動ブラケットベース	1
84		SM-6051402-TP	SCREW M5X0.8 L=14	六角穴ボルト M5X0.8 L=14	4
85		401-16071	Y DRIVEN BRACKET BASE	Y 従動ブラケットベース	1
86		SM-6051402-TP	SCREW M5X0.8 L=14	六角穴ボルト M5X0.8 L=14	4
87		SL-6052092-TN	SCREW M5 L=20	座金付き六角穴ボルト M5 L=20	1
88		G6206-875-000	STOPPER BOLT	ストップボルト	2
89		SM-6040602-TP	SCREW M4X0.7 L=6	六角穴ボルト M4X0.7 L=6	1
90		WP-0430801-SC	WASHER M4	平座金 M4	1
91		WS-0410002-KP	SPRING WASHER	ばね座金 M4	1
92		401-05169	XY CORD SUPPORT ROD	XY コード支え棒	1
93		SL-6041292-TN	SCREW M4 L=12	座金付き六角穴ボルト M4 L=12	2

18. X-Y DRIVER UNIT (2)
 X - Y 駆動機構 (2)

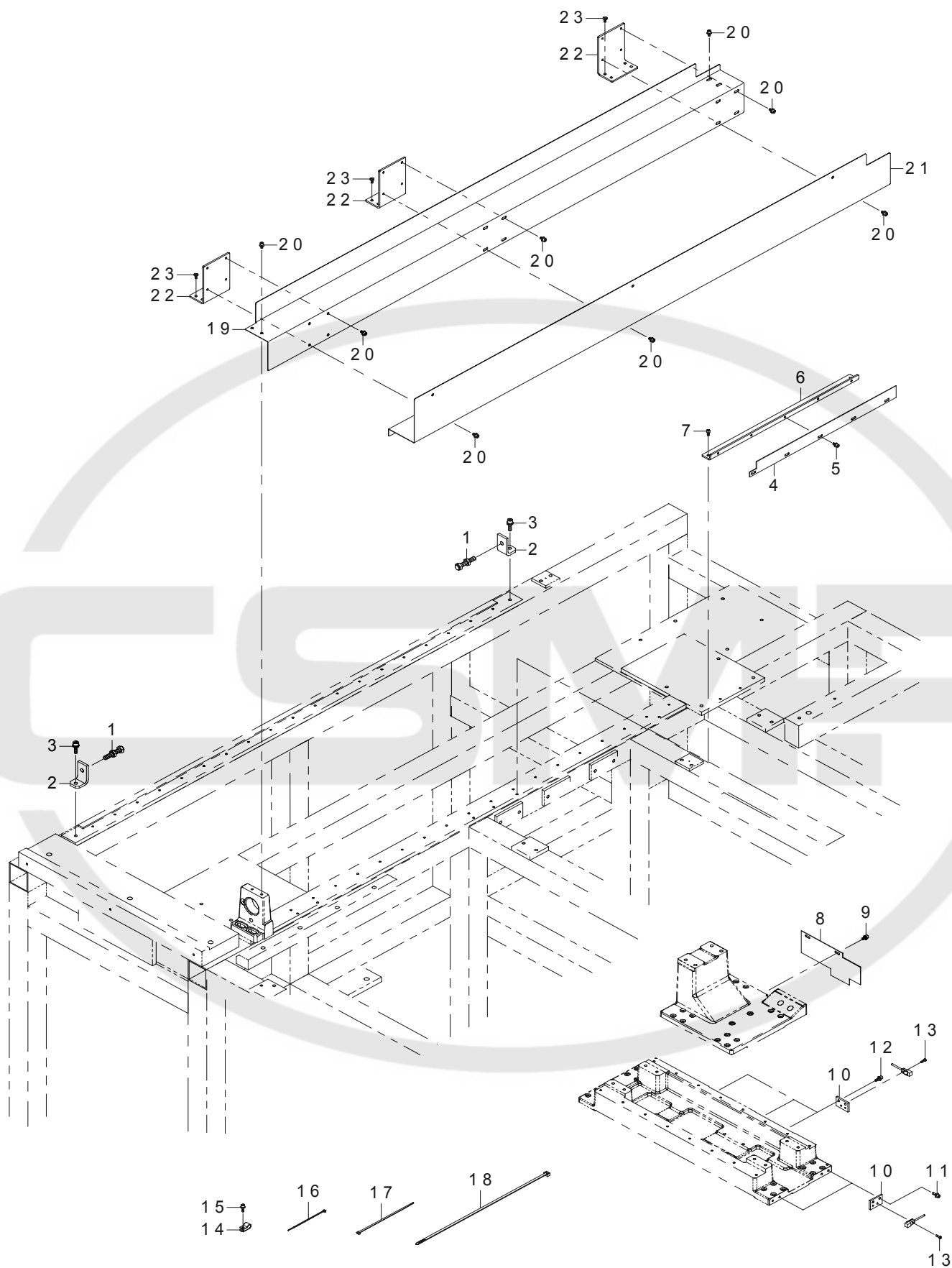

REF.NO	NOTE	PART NO	DESCRIPTION	品名	Qty
1		G6206-875-000	STOPPER BOLT	ストッパーボルト	2
2		401-16072	STOPPER FITTING PLATE	ストッパー取付板	2
3		SL-6062092-TN	SCREW M6 L=20	座金付き六角穴ボルト M 6 L = 20	2
4		401-16073	X SENSOR SLIT	X センサスリット	1
5		SL-6040892-TN	SCREW M4 L=8	座金付き六角穴ボルト M 4 L = 8	5
6		401-16074	X SLIT FITTING PLATE	X センサスリット取付板	1
7		SM-6040860-TP	SCREW M4 L=8	平ねじ	2
8		401-16075	Y SENSOR SLIT	Y センサスリット	1
9		SL-6040892-TN	SCREW M4 L=8	座金付き六角穴ボルト M 4 L = 8	2
10		401-16076	SENSOR FITTING PLATE	X センサ取付板	5
11		SL-6041292-TN	SCREW M4 L=12	座金付き六角穴ボルト M 4 L = 12	4
12		SL-6041292-TN	SCREW M4 L=12	座金付き六角穴ボルト M 4 L = 12	6
13		SM-4031001-SC	SCREW M3X0.5 L=10	なべ小ねじ M 3 X 0. 5 L = 10	5
14		HX-0015000-0C	CABLE CLAMP	ケーブルクリップ	6
15		SL-6041292-TN	SCREW M4 L=12	座金付き六角穴ボルト M 4 L = 12	6
16		EA-9500B01-00	CABLE BAND	束線バンド	100
17		EA-9500B02-00	CABLE BAND	束線バンド	100
18		G5453-161-000	CABLE BAND	束線バンド	10
19		401-16077	SPLINE SHAFT COVER A	スプライン軸カバー A	1
20		SL-6040892-TN	SCREW M4 L=8	座金付き六角穴ボルト M 4 L = 8	16
21		401-16078	SPLINE SHAFT COVER B	スプライン軸カバー B	1
22		401-16079	SPLINE SHAFT COVER FITTING PLATE	スプライン軸カバー取付板	3
23		SM-6040860-TP	SCREW M4 L=8	平ねじ	6

CSMP

19. CLOTH PRESSER COMPONENTS

布押え関係

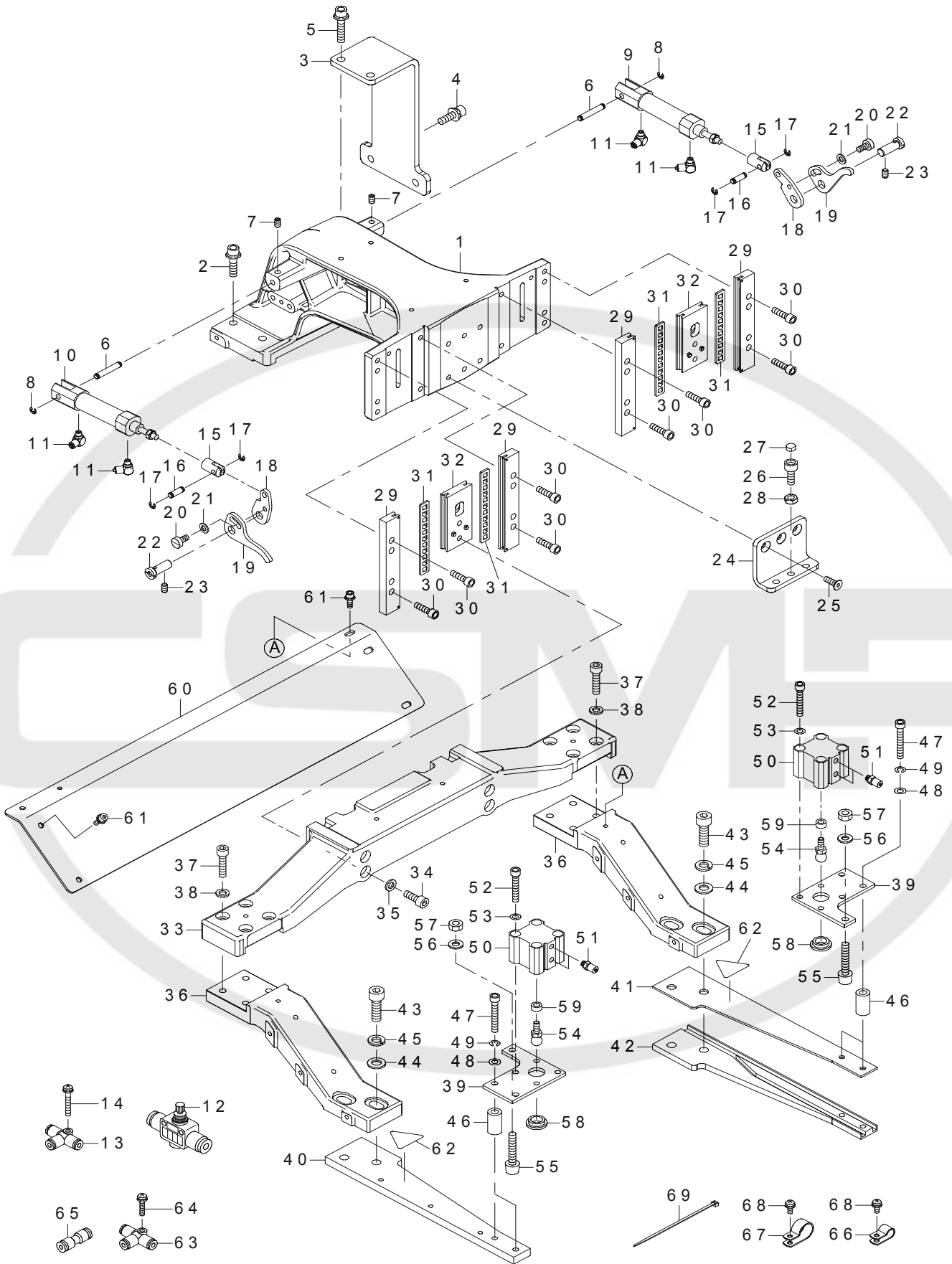

REF.NO	NOTE	PART NO	DESCRIPTION	品名	Qty
1		401-16080	CLOTH FEED BASE	布送り台	1
2		SL-6062592-TN	SCREW M6 L=25	座金付き六角穴ボルト M 6 L = 25	2
3		401-16081	GUARD PLATE	ガード板	1
4		SL-6062092-TN	SCREW M6 L=20	座金付き六角穴ボルト M 6 L = 20	2
5		SL-6063092-TN	SCREW M6 L=30	座金付き六角穴ボルト M 6 L = 30	2
6		B1504-210-000	CONNECTING SHAFT	ソレノイド連結軸	2
7		SM-8050812-TP	SCREW M5X8	止めねじ M 5 X 8	2
8		RE-0320000-K0	E-RING 3.2	E 形止め輪 3. 2	2
9		401-05072	UPPER BIG CLAMP CYLINDER ASSY	布押え大上シリンダー組	1
10		401-05073	LOWER BIG CLAMP CYLINDER ASSY	布押え大下シリンダー組	1
11		PJ-3040405-04	UNION	ユニオン	4
12		PC-0124010-00	SPEED CONTROLLER	スピードコントローラ	2
13		PJ-3050400-01	T	チーズ	2
14		SL-4043091-SC	SCREW M4 L=30	座金付きなべ小ねじ M 4 L = 30	1
15		400-23644	CYLINDER KNUCKLE	押えシリンダナックル	2
16		400-23635	CYLINDER PIN	シリンダ接続ピン	2
17		RE-0300000-K0	E-RING 3	E 形止め輪 3	4
18		400-32229	LIFTING LEVER A	布押えレバー A	2
19		400-85820	LIFTING LEVER B	布押えレバー B	2
20		SM-6051000-SP	SCREW	平ねじ M 5 L = 10	2
21		WP-0531000-SD	WASHER M5	平座金小形丸 M 5	2
22		260-23408	FEED STUD	送り軸	2
23		SM-8050812-TP	SCREW M5X8	止めねじ M 5 X 8	2
24		401-16082	STOPPER MOUNTING PLATE	ストッパー板	1
25		SM-1051452-TN	PLATE SCREW	皿ねじ M 5 L = 14	3
26		400-09236	STOP SCREW	起動リンクストッパー	2
27		B1432-761-000	SWING ARM STOPPER RUBBER	キセン変換押し棒ブッシュ	2
28		NS-6150430-SP	HEXAGONAL NUT 15/64-28	六角ナット 15/64-28	2
29		401-16083	WORK CLAMP FOOT PLATE B ASM.	布押え滑り板 B 組	4
30		SM-6051802-TP	SCREW M5 L=18	六角穴ボルト M 5 L = 18	12
31		401-16085	BEARING	滑り板ベアリング	4
32		400-85830	SLIDE PLATE ASM.	布押え足滑り板組	2
33		401-16086	FEEDING FRAME ARM A	押さえ腕 A	1
34		SM-6061602-TN	SCREW M6 L=16	六角穴ボルト M 6 L = 16	4
35		WP-0641600-SC	WASHEW 6.4X12.5X1.6	平座金	4
36		401-16087	FEEDING FRAME ARM B	押さえ腕 B	2
37		SM-6062502-TN	SCREW	六角穴ボルト	8
38		WP-0641600-SC	WASHEW 6.4X12.5X1.6	平座金	8
39		G5501-875-000	FITTING PLATE	布押えシリンダ取付板	2
40		G5502-875-000	CLOTH PRESSER ARM LEFT	布押え腕 左	1
41		G5503-875-000	CLOTH PRESSER ARM RIGHT UPPER	布押え腕 右上	1
42		G5504-875-000	CLOTH PRESSER ARM RIGHT LOWER	布押え腕 右下	1
43		SM-6082502-TN	SCREW	六角穴ボルト	4
44		WP-0841600-SC	WASHER	平座金	4
45		WS-0820002-KN	SPRING WASHER M8	ばね座金 M 8	4
46		D2419-530-D00	MAGNET ARM BUSHING	マグネット腕座	4
47		SM-6053502-TN	SCREW M5 L=35	六角穴ボルト M 5 L = 35	4
48		WP-0531001-SC	WASHER M5	平座金みがき丸 M 5	4
49		WS-0510002-KN	SPRING WASHER M5	ばね座金 M 5	4
50		PA-2001004-A0	AIR CYLINDER	エアシリンダ	2
51		PJ-0320525-03	HOSE NIPPLE	ホースニップル	4
52		SM-6053002-TN	SCREW M5X0.8 L=30	六角穴ボルト M 5 X 0. 8 L = 30	8
53		WS-0510002-KN	SPRING WASHER M5	ばね座金 M 5	8
54		G5511-875-000	BALL	ボール	2
55		GAK-01003B00	PRESSER LIFTER STOPPER B	押え上げストッパー B	2
56		WP-0641601-SC	WASHER M6	平座金みがき丸 M 6	2
57		NM-6060001-SC	NUT M6X1 TYPE1	六角ナット M 6 X 1 1種	2
58		GLA-02302000	FULCRUM BUSHING	支点軸受	2
59		115-28809	WASHER	差動調節目盛板座金	2
60		401-16088	STIFFENING PLATE	補強板	1
61		SL-6041292-TN	SCREW M4 L=12	座金付き六角穴ボルト M 4 L = 12	6
62		CM-3002000-03	FINGER INJURY CAUTION LABEL (31.5)	指怪我注意シール (31. 5)	2
63		PJ-3050400-01	T	チーズ	2
64		SL-4042091-SC	SCREW M4 L=20	座金付きなべ小ねじ M 4 L = 20	2
65		PJ-3030400-02	STRAIGHT UNION 4	ストレートユニオン 4	2
66		HX-0015000-0C	CABLE CLAMP	ケーブルクリップ	12
67		HX-0015000-0G	CABLE CLAMP	ケーブルクリップ	13
68		SL-4041091-SC	SCREW M4 L=10	座金付きなべ小ねじ M 4 L = 10	25
69		EA-9500B01-00	CABLE BAND	束線バンド	6

20. FITTING PLATE COMPONENTS

折り機関係

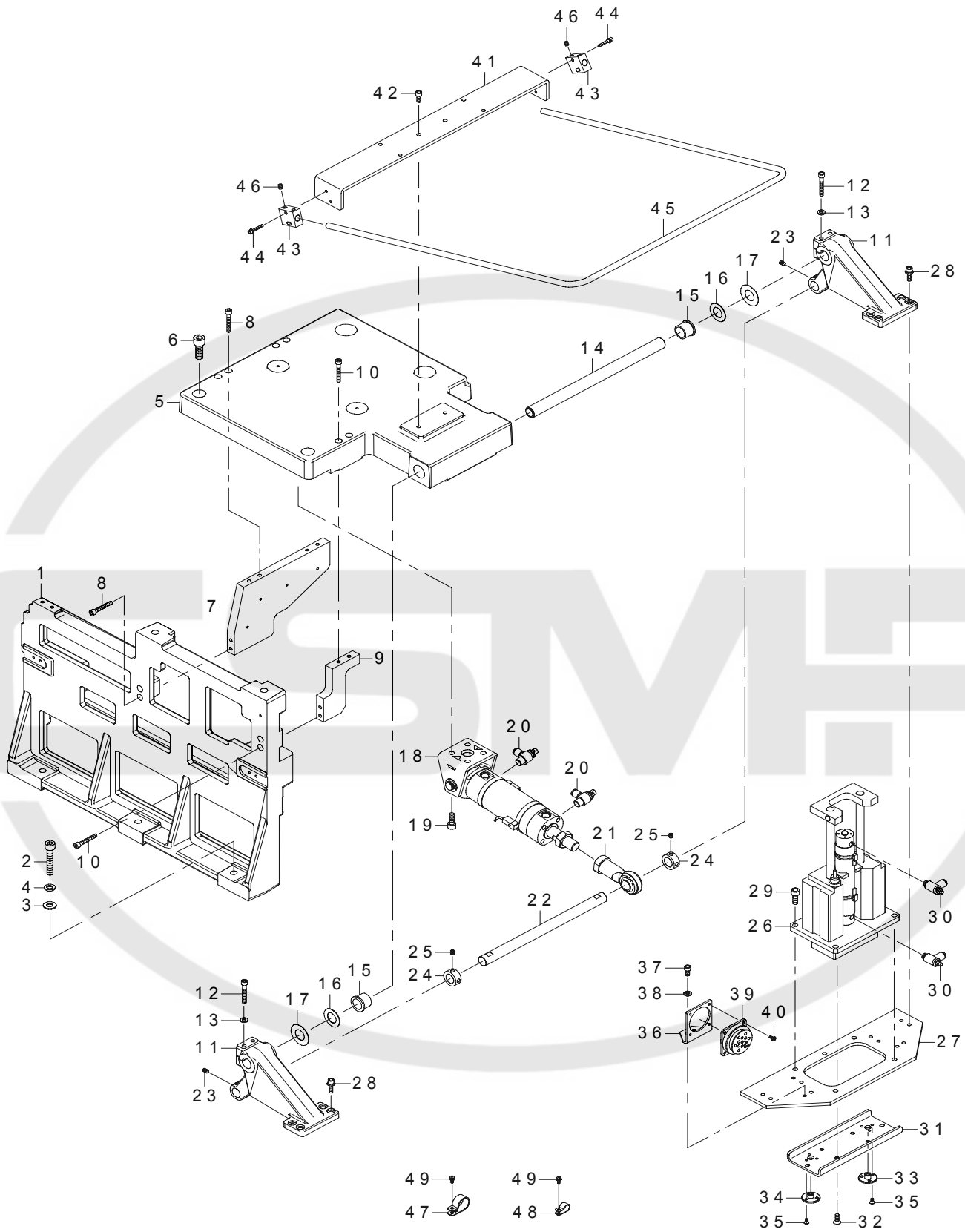

REF.NO	NOTE	PART NO	DESCRIPTION	品名	Qty
1		401-16090	MAIN BASE A	折り機土台 A	1
2		SM-6105502-TN	SCREW M10 L=55	六角穴ボルト M=10 L=55	3
3		WP-1052001-SC	WASHER 10	平座金みがき丸 M10	3
4		WS-1020002-KN	SPRING WASHER M10	ばね座金 M10	3
5		401-16091	MAIN BASE B	折り機土台 B	1
6		SM-6123002-TN	SCREW M12 L=30	六角穴ボルト M12 L=30	2
7		401-16092	BEAM A	梁 A	1
8		SM-6064002-TP	SCREW M6 L=40	六角穴ボルト M6 L=40	6
9		401-16093	BEAM B	梁 B	1
10		SM-6064002-TP	SCREW M6 L=40	六角穴ボルト M6 L=40	4
11		401-16094	ARM	折り腕	2
12		SM-6064002-TN	SCREW	六角穴ボルト	4
13		WP-0641601-SC	WASHER M6	平座金みがき丸 M6	4
14		401-16095	FOLDING BASE SHAFT	折り土台軸	1
15		G6023-870-000	SUPPORT BASE SHAFT METAL	支持ベース軸メタル	2
16		G6028-870-000	FOLDING BASE SHAFT STARTING CIRCLE	折りベース軸軌道輪	2
17		G6040-870-000	SHIM	折り腕位置調整シム	2
18		401-05070	ORUD CYLINDER ASSY	折り腕シリンダー組	1
19		SM-6082002-TP	SCREW M8 L=20	六角穴ボルト M8 L=20	4
20		PC-0152030-00	SPEED CONTROLLER	スピードコントローラ	2
21		401-16096	ROD END	ロッドエンド	1
22		401-16097	FOLDING ARM SHAFT	折り腕軸	1
23		SM-8060812-TP	SCREW M6 L=8	止めねじ M6 L=8	4
24		CS-1801211-SH	THRUST COLLAR D=18 W=12	スラスト受 D=18 W=12	2
25		SS-8660612-TP	SCREW 1/4-40 L=6	止めねじ 1/4-40 L=6	4
26		401-05071	ORKI CYLINDER ASSY	折り機シリンダー組	1
27		401-16098	CYLINDER FITTING PLATE	折り上下シリンダ取付板	1
28		SL-6062092-TN	SCREW M6 L=20	座金付き六角穴ボルト M6 L=20	8
29		SM-6082002-TN	SCREW M8 L=20	六角穴ボルト M8 L=20	4
30		PC-0151060-00	SPEED CONTROLLER	スピードコントローラ	2
31		401-16099	CREASE GAGE COM. INSTALLING PLATE	折り機取付板	1
32		SM-1061652-TP	SCREW M6 L=16	皿小ねじ M6 L=16	4
33		G6028-875-000	GAUGE PIN HOLDER	位置決めピン受け	1
34		G6029-875-000	GAUGE PIN HOLDER B	位置決めピン受け B	1
35		SM-1040801-SC	SCREW M4X0.7 L=8	皿小ねじ M4 X 0.7 L=8	6
36		G6010-870-000	CONNECTOR FITTING PLATE	コネクタ取付板	1
37		SM-6061202-TN	SCREW	六角穴ボルト	2
38		WP-0641601-SC	WASHER M6	平座金みがき丸 M6	2
39		PJ-4010003-00	MULTI CONNECTOR (SOCKET SIDE)	マルチコネクタ (ソケット側)	1
40		SM-4040801-SN	SCREW M4 L=8	なべ小ねじ M4 X 0.7 L=8	4
41		G6008-875-000	FITTING PLATE	折り機ガード取付板	1
42		SM-6061402-TN	SCREW	六角穴ボルト	2
43		401-16261	GUARD PIPE HOLDER	ガードパイプ取付台	2
44		SL-6042592-TN	SCREW M4 L=25	座金付き六角穴ボルト M4 L=25	4
45		401-16100	FOLDING UNIT GUARD PIPE	折り機ガードパイプ	1
46		SM-8060812-TP	SCREW M6 L=8	止めねじ M6 L=8	4
47		HX-0015000-0M	CABLE CLAMP	ケーブルクリップ	1
48		HX-0015000-0E	CABLE CLAMP	ケーブルクリップ	2
49		SL-4041091-SC	SCREW M4 L=10	座金付きなべ小ねじ M4 L=10	3

21. FORM PLATE MECHANISM COMPONENTS

型板機構關係

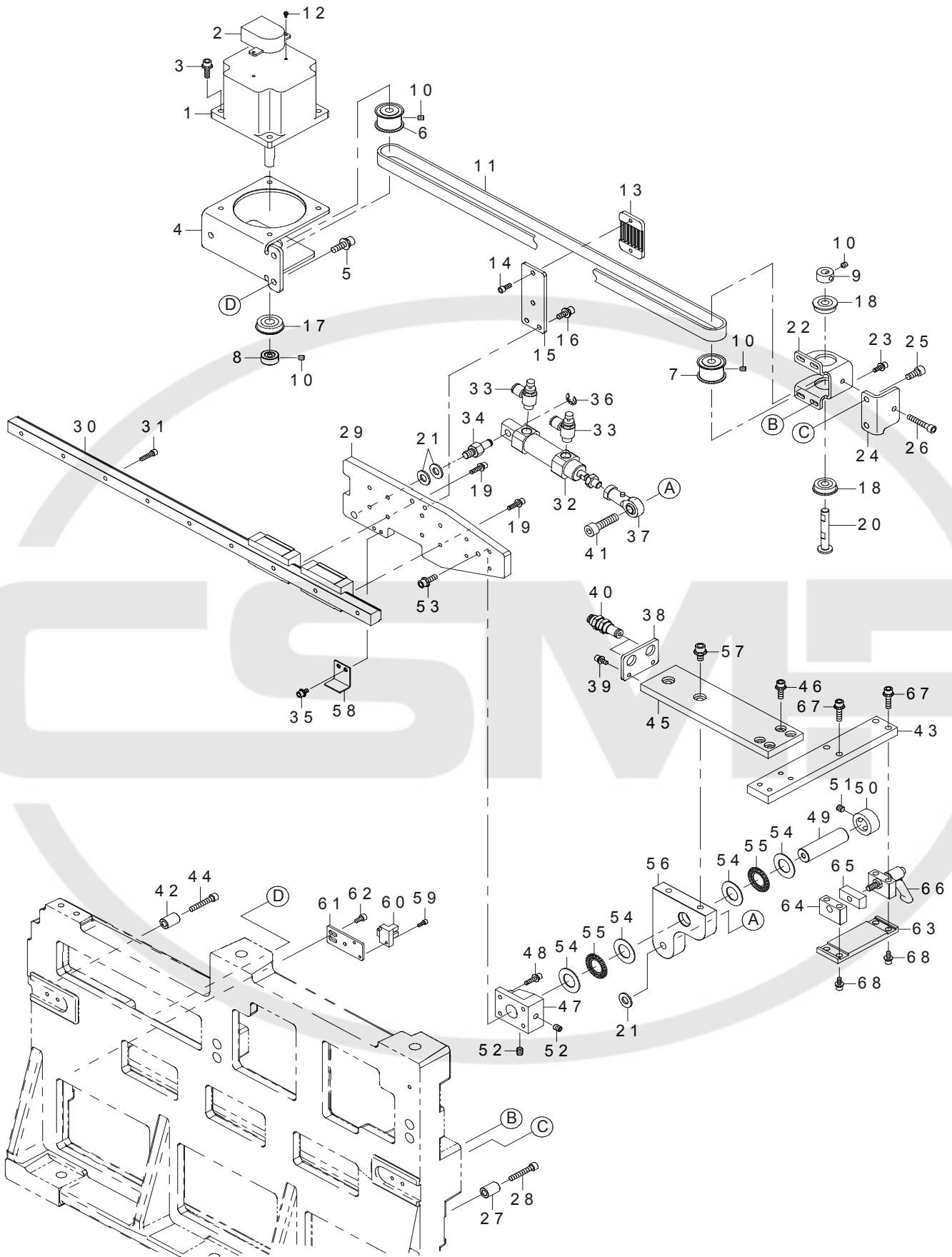

REF.NO	NOTE	PART NO	DESCRIPTION	品名	Qty
1		400-71944	STEPPING MOTOR	ステッピングモータ	1
2		HD-0027800-00	SENSOR	センサー	1
3		SL-6051692-TN	SCREW M5 L=16	座金付き六角穴ボルト M5 L=16	4
4		401-16429	MOTOR FITTING PLATE	型板モータ取付け板	1
5		SL-6062092-TN	SCREW M6 L=20	座金付き六角穴ボルト M6 L=20	3
6		401-16430	DRIVE SPROCKET	源動プーリー	1
7		401-16431	DRIVEN SPROCKET	従動プーリー	1
8		CS-1000881-TP	THRUST COLLAR D=10 W=8	スラスト受 D=10 W=8	1
9		CS-0800971-TP	THRUST COLLAR D=8 W=9	スラスト受 D=8 W=9	1
10		SM-8050602-TP	SCREW M5 L=6	止めねじ M5 X 0.8 L=6	8
11		401-16432	PATTERN BOARD TIMING BELT	型板搬送ベルト	1
12		SL-4020591-SC	SCREW M2 L=5	座金付きなべ小ねじ M2 L=5	2
13		400-32219	BELT RECEIVER	ベルト押え	1
14		SL-6051492-TN	SCREW M5 L=14	座金付き六角穴ボルト M5 L=14	2
15		401-16433	BELT RECEIVER FITTING PLATE	ベルト押え取付け板	1
16		SL-6051492-TN	SCREW M5 L=14	座金付き六角穴ボルト M5 L=14	2
17		SB-1100013-00	BEARING	ころがり軸受	1
18		SB-1080005-00	BEARING	ころがり軸受	2
19		SL-6041692-TN	SCREW M4 L=16	座金付き六角穴ボルト M4 L=16	8
20		401-16435	DRIVEN SPROCKET SHAFT	プーリーシャフト	1
21		WP-0841601-SC	WASHER M8	平座金みがき丸 M8	3
22		400-77991	X DRIVEN BRACKET	X 従動ブラケット	1
23		SL-6041292-TN	SCREW M4 L=12	座金付き六角穴ボルト M4 L=12	4
24		401-16436	PRESSER BASE PLATE	荷重支え板	1
25		SM-6061402-TN	SCREW	六角穴ボルト	2
26		SM-6053002-TN	SCREW M5X0.8 L=30	六角穴ボルト M5 X 0.8 L=30	1
27		GAC-01002A00	COLLAR	ソレノイド取付台座金	1
28		SM-6053002-TN	SCREW M5X0.8 L=30	六角穴ボルト M5 X 0.8 L=30	1
29		401-16437	FORM PLATE SLIDER PLATE	型板スライド板	1
30		401-16438	CARRIER SLIDE GUIDE	搬送LMガイド	1
31		SM-6041602-TP	SCREW M4X0.7 L=16	六角穴ボルト M4 X 0.7 L=16	9
32		PA-2000511-00	AIR CYLINDER	エアシリンダ	1
33		PC-0151080-00	SPEED CONTROLLER	スピードコントローラ	2
34		400-35137	CYLINDER SHAFT B	シリンダー軸 B	1
35		SL-6040892-TN	SCREW M4 L=8	座金付き六角穴ボルト M4 L=8	2
36		RE-0700000-K0	E-RING 7	E 形止め輪 7	1
37		400-35314	ROD END	シリンダーロッド	1
38		401-16439	UNION BRACKET	ラベルチューブ取付け板	1
39		SL-6041092-TN	SCREW M4 L=10	座金付き六角穴ボルト M4 L=10	2
40		PJ-2300043-00	PARTITION UNION 4	隔壁用ユニオン 4	2
41		SM-6083002-TP	SCREW M8 L=30	六角穴ボルト M8 L=30	1
42		400-11758	SYNCHRONIZER BASE COLLAR	シンクロ取付板カラー	1
43		401-16440	CARRIER SRIDE ARM A	型板腕 A	1
44		SM-6064002-TP	SCREW M6 L=40	六角穴ボルト M6 L=40	1
45		401-16441	CARRIER SRIDE ARM B	型板腕 B	1
46		SL-6051692-TN	SCREW M5 L=16	座金付き六角穴ボルト M5 L=16	4
47		401-16442	CARRIER BOSS BLOCK	型板ボスブロック	1
48		SL-6041692-TN	SCREW M4 L=16	座金付き六角穴ボルト M4 L=16	4
49		401-16443	CARRIER SHAFT	型板シャフト	1
50		CS-1601211-TH	THRUST COLLAR D=16 W=12	スラスト受 D=16 W=12	1
51		SS-8660612-TP	SCREW 1/4-40 L=6	止めねじ 1/4-40 L=6	2
52		SM-8060812-TP	SCREW M6 L=8	止めねじ M6 L=8	2
53		SL-6051692-TN	SCREW M5 L=16	座金付き六角穴ボルト M5 L=16	1
54		G5523-880-000	THRUST WASHER B	スラスト座金 B	4
55		SB-6160001-00	BEARING	ころがり軸受	2
56		401-16444	CARRIER SRIDE ARM C	型板腕 C	1
57		SL-6061292-TN	SCREW M6 L=12	座金付き六角穴ボルト M6 L=12	2
58		401-16445	SENSOR PLATE	原点検知板	1
59		SM-6030802-TN	SCREW	六角穴ボルト	1
60		HD-0005700-0A	SENSOR	フォトセンサ	1
61		B4004-210-D00	X SENSOR INSTALLING PLATE	X センサー取付板	1
62		SM-6040802-TN	SCREW M4X0.7 L=8	六角穴ボルト M4 X 0.7 L=8	2
63		G6108-870-000	ONE-TOUCH BASE PLATE B	ワンタッチベース板 B	1
64		G6012-870-000	ONE TOUCH BASE CONNECTING PLATE	ワンタッチベース接続板	1
65		G6014-870-000	ONE TOUCH LOCK METAL B	ワンタッチロック金具 B	1
66		G6016-870-0A0	LOOK LEVER SHAFT B ASM.	ロックレバー軸 B 結合	1
67		SL-6062092-TN	SCREW M6 L=20	座金付き六角穴ボルト M6 L=20	4
68		SM-6061202-TN	SCREW	六角穴ボルト	4

22. VERTICAL TABLE COMPONENTS

テーブル上下機構関係

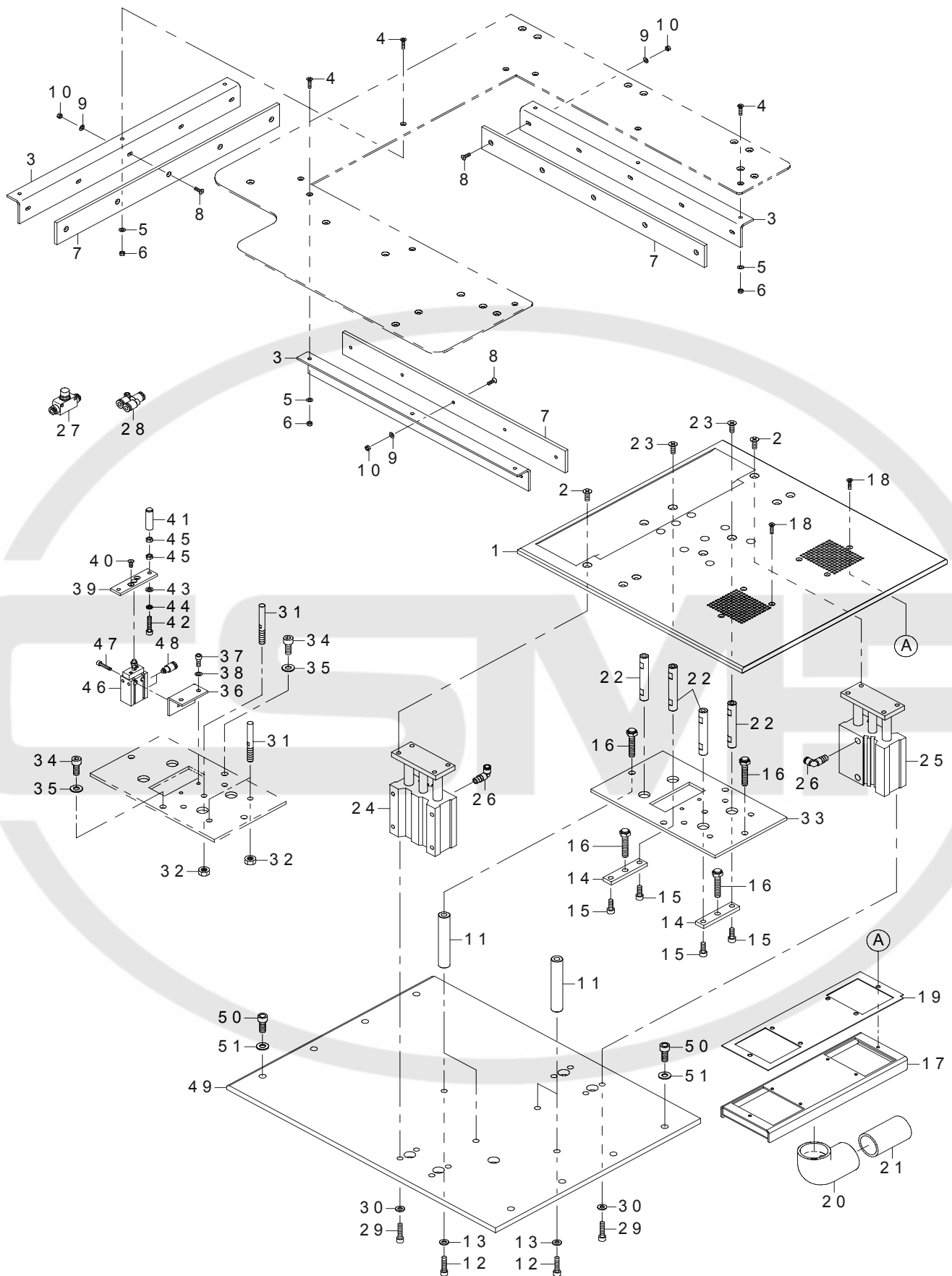

REF.NO	NOTE	PART NO	DESCRIPTION	品名	Qty
1		401-16101	LIFTING TABLE	昇降テーブル	1
2		SM-1061601-SC	SCREW M6 L=16	皿小ねじ M6 L=16	6
3		G6202-875-000	TABLE GUIDE FITTING PLATE	テーブルガイド取付板	3
4		SM-1041601-SC	SCREW M4X0.7 L=16	皿小ねじ M4X0.7 L=16	9
5		WP-0430801-SC	WASHER M4	平座金 M4	9
6		NM-6040001-SC	NUT M4X0.7 TYPE1	六角ナット M4X0.7 1種	9
7		G6203-875-000	TABLE GUIDE PLATE	テーブルガイド板	3
8		SM-1041201-SC	SCREW M4 L=12	皿小ねじ M4X0.7 L=12	15
9		WP-0430801-SC	WASHER M4	平座金 M4	15
10		NM-6040001-SC	NUT M4X0.7 TYPE1	六角ナット M4X0.7 1種	15
11		G6204-875-000	TABLE STOPPER FITTING SHAFT	テーブルストッパ取付軸	4
12		SM-6062502-TN	SCREW	六角穴ボルト	4
13		WP-0611626-SP	WASHER 15X6X1.6	平座金	4
14		G6205-875-000	TABLE STOPPER FITTING PLATE	テーブルストッパ取付板	2
15		SM-6061602-TN	SCREW M6 L=16	六角穴ボルト M6 L=16	4
16		G6206-875-000	STOPPER BOLT	ストッパボルト	4
17		G6207-875-000-A	VACUUM BOX	バキュームボックス	1
18		SM-1041601-SC	SCREW M4X0.7 L=16	皿小ねじ M4X0.7 L=16	6
19		G6208-875-000-A	PACKING	パッキン	1
20		G6211-875-000	VACUUM BOX ELBOW	バキュームボックスエルボ	1
21		250-23300	PIPE	吐出しパイプ	1
22		401-16102	STOPPER SHAFT	ストッパ軸	4
23		SM-1061601-SC	SCREW M6 L=16	皿小ねじ M6 L=16	4
24		401-05069	TABLE CYLINDER ASSY	テーブル上下シリンダー組	1
25		PA-2505003-00	AIR CYLINDER	エアシリンダ	1
26		PJ-3040651-01	ELBOW UNION 6XPT1/8	エルボユニオン 6XPT1/8	4
27		PC-0126010-00	SPEED CONTROLLER	スピードコントローラ	2
28		PJ-3080600-03	UNION Y	ユニオンワイ	2
29		SM-6062502-TN	SCREW	六角穴ボルト	8
30		WP-0641601-SC	WASHER M6	平座金みがき丸 M6	8
31		G6210-875-000	TENPLATE GAUGE PIN	型板位置決めピン	3
32		NM-6080001-SC	NUT M8X1.25 TYPE1	六角ナット M8X1.25 1種	3
33		401-16103	BASE PLATE	身頃押さえベース板	1
34		SM-6082002-TN	SCREW M8 L=20	六角穴ボルト M8 L=20	2
35		WP-0841601-SC	WASHER M8	平座金みがき丸 M8	2
36		G6213-875-000	CYLINDER FITTING PLATE	シリンダー取付板	1
37		SM-6051402-TN	SCREW M5 L=14	六角穴ボルト M5 L=14	2
38		WP-0531001-SC	WASHER M5	平座金みがき丸 M5	2
39		G6214-875-000	GARMENT PRESSER FITTING PLATE	身頃押さえ取付板	1
40		SM-1041001-SC	SCREW M4X0.7 L=10	皿小ねじ M4X0.7 L=10	2
41		G6215-875-0A0	GARMENT PRESSER PIN ASM.	身頃押さえピン組	2
42		SM-6052502-TN	SCREW	六角穴ボルト	2
43		WP-0531001-SC	WASHER M5	平座金みがき丸 M5	2
44		WS-0510002-KN	SPRING WASHER M5	ばね座金 M5	2
45		NM-6050001-SC	NUT M5X0.8 TYPE1	六角ナット M5X0.8 1種	4
46		PA-1601515-A0	AIR CYLINDER	エアシリンダ	1
47		SM-6042002-TN	SCREW	六角穴ボルト	2
48		PJ-3010405-02	HALF UNION 4XM5	ハーフユニオン 4XM5	2
49		401-16104	TABLE BASE PLATE	テーブル土台	1
50		SM-6082002-TN	SCREW M8 L=20	六角穴ボルト M8 L=20	8
51		WP-0841601-SC	WASHER M8	平座金みがき丸 M8	8

23. SUCTION DEVICE COMPONENTS

吸引装置関係

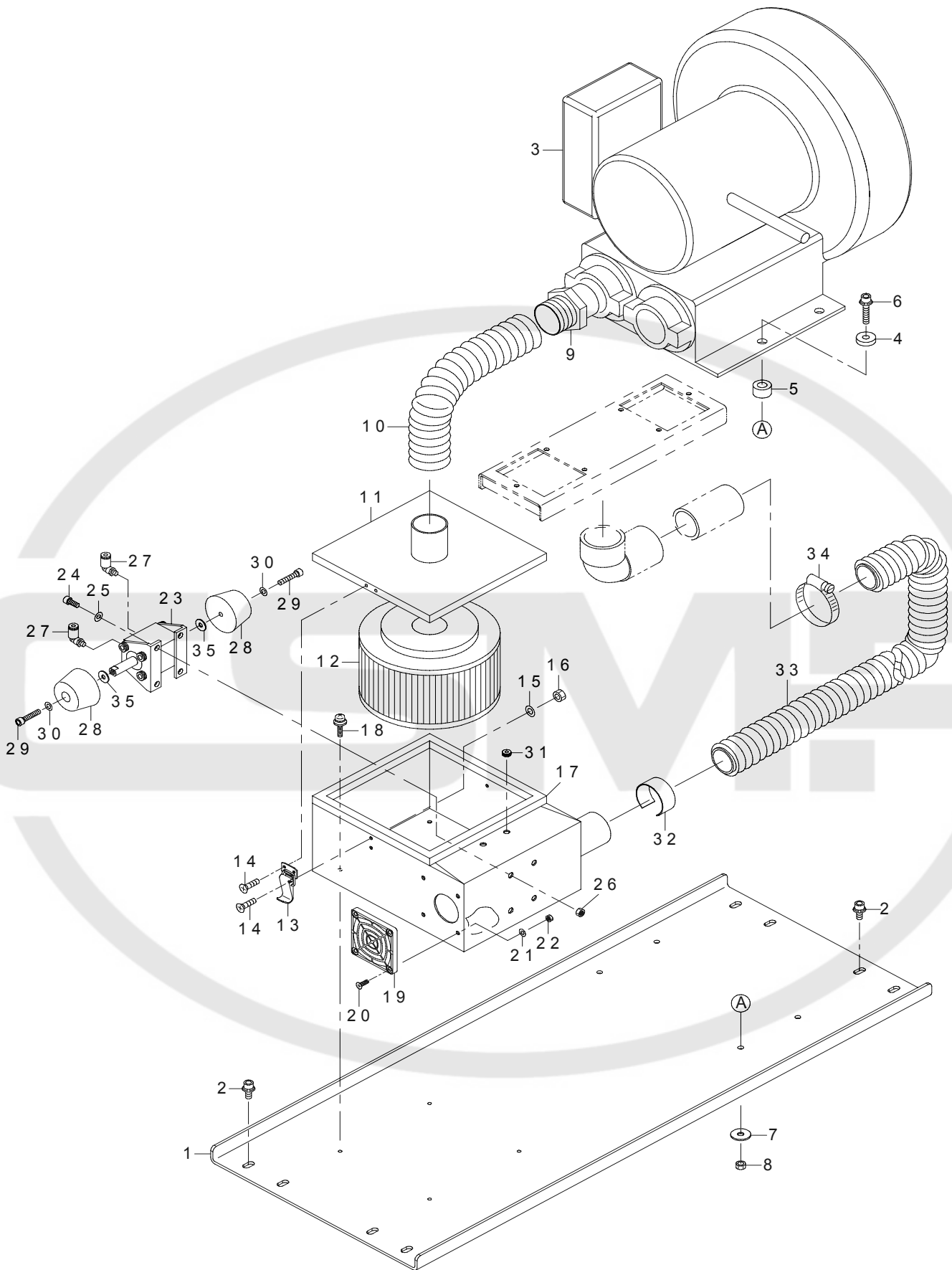

REF.NO	NOTE	PART NO	DESCRIPTION	品名	Qty
1		401-16165	CLOTH SUCTION BASE PLATE	吸引装置土台取付け板	1
2		SL-6061492-TN	SCREW M6 L=14	座金付き六角穴ボルト M6 L=14	8
3		G6951-172-CA0	HITACHI POWER CORD COMPL.	日立フロア電源コード完成品	1
4		B4420-373-000	CUSHION	遮断クッション	4
5		B1123-205-000	RUBBER PAD	防振ゴム B	4
6		SL-6063042-TN	SCREW M6 L=30	座金付き六角穴ボルト M6 L=30	4
7		WP-0651646-SC	WASHER	平座金	4
8		NM-6060001-SC	NUT M6X1 TYPE1	六角ナット M6 X 1 1種	4
9		G5345-172-000	BLOWER JOINT	ブロウ継手	1
10		G5344-172-000	VACUUM HOSE	バキュームホース B	1
11		GMC-100050A0	TOP COVER ASM.	上蓋組	1
12		GMC-10004000	FILTER ELEMENT	フィルターエレメント	1
13		GMC-10007000	METAL FITTINGS	上蓋止金具	2
14		SM-1030801-SC	SCREW M3 L=8	皿小ねじ M3 X 0.5 L=8	8
15		WP-0320501-SC	WASHER M3	平座金 M3	4
16		NM-6030001-SC	NUT M3X0.5 TYPE1	六角ナット M3 X 0.5 1種	4
17		G6252-875-0A0	FILTER BOX ASM.	フィルタボックス組	1
18		SL-4040891-SC	SCREW M4X8	座金付きなべ小ねじ M4 L=8	4
19		HM-0005500-10	FAN MOTOR	ファン用フィルタ	1
20		SM-1041201-SC	SCREW M4 L=12	皿小ねじ M4 X 0.7 L=12	4
21		WP-0430801-SC	WASHER M4	平座金 M4	4
22		NM-6040001-SC	NUT M4X0.7 TYPE1	六角ナット M4 X 0.7 1種	4
23		PA-2002011-00	CYLINDER	シリンダ	1
24		SM-6051202-TN	SCREW M5X0.8 L=12	六角穴ボルト M5 X 0.8 L=12	4
25		WP-0531001-SC	WASHER M5	平座金みがき丸 M5	4
26		NM-6050001-SC	NUT M5X0.8 TYPE1	六角ナット M5 X 0.8 1種	4
27		PJ-3040405-04	UNION	ユニオン	2
28		G6253-875-000	VACUUM CHANGE RUBBER	バキューム切替ゴム	2
29		SM-6052502-TN	SCREW	六角穴ボルト	2
30		WP-0531001-SC	WASHER M5	平座金みがき丸 M5	2
31		HX-0005500-00	GROMMET	ブッシュ	2
32		G5171-136-000	VACUUM CONTROL PLATE	バキューム調節金具	1
33		GMC-16005000	HOSE (L)	布吸引ホース (L)	1
34		G5176-136-000	HOSE BAND	ホースバンド	4
35		WP-0501046-SC	WASHER 5X14X1	平座金 5 X 14 X 1	2

24. AIR PRESSURE COMPONENTS

空圧関係

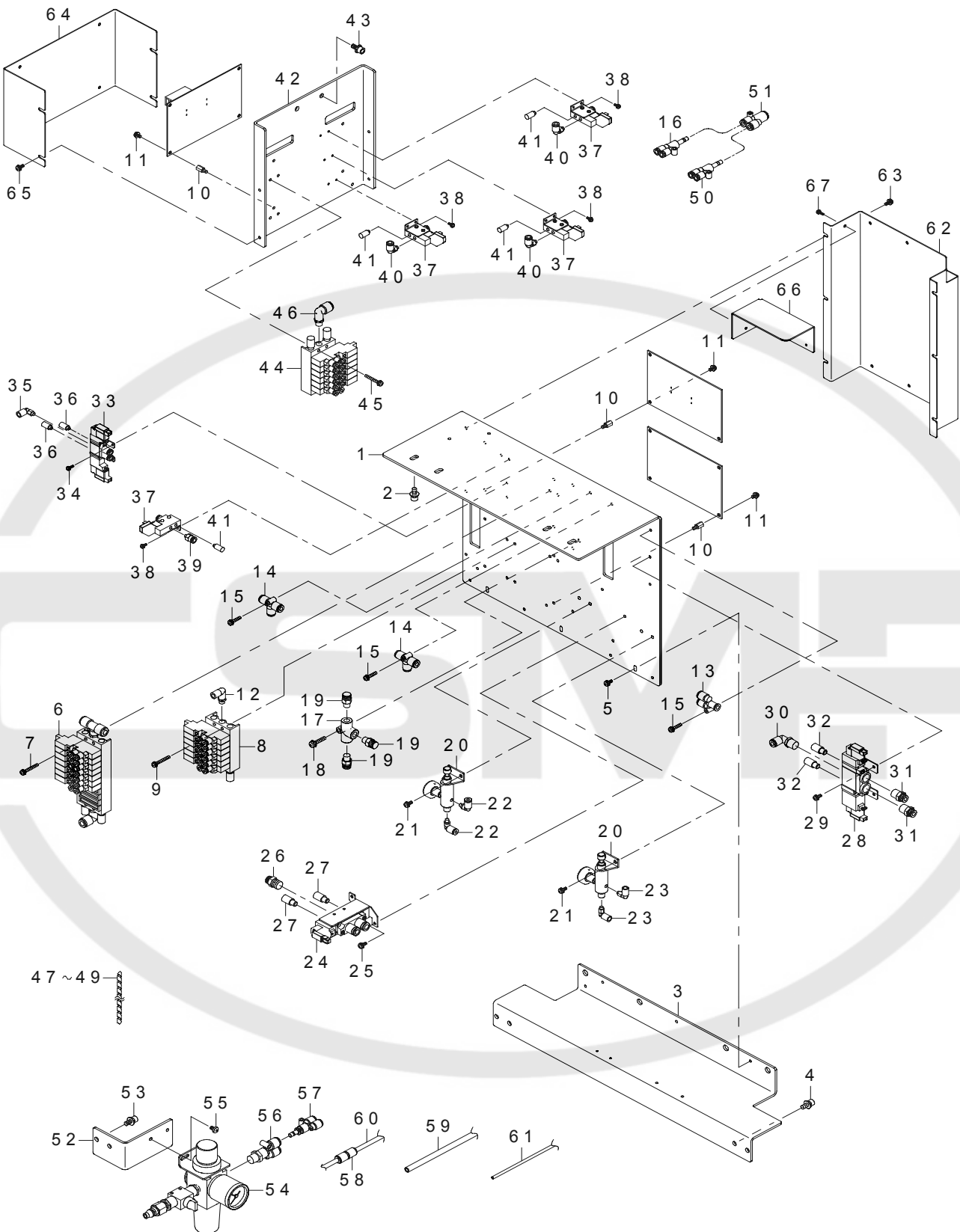

REF.NO	NOTE	PART NO	DESCRIPTION	品名	Qty
1		401-16205	SOLENOID VALVE MOUNTING PLATE	電磁弁取付け板	1
2		SL-6061492-TN	SCREW M6 L=14	座金付き六角穴ボルト M6 L=14	4
3		401-16206	SOLENOID MOUNTING SPPORT PLATE	電磁弁取付け板支え板	1
4		SL-6061492-TN	SCREW M6 L=14	座金付き六角穴ボルト M6 L=14	4
5		SL-4041091-SC	SCREW M4 L=10	座金付きなべ小ねじ M4 L=10	3
6		401-16207	ASSY MANIFOLD VALVE 11	マニホールドバルブ組 11連	1
7		SL-4043091-SC	SCREW M4 L=30	座金付きなべ小ねじ M4 L=30	4
8		401-16208	ASSY MANIFOLD VALVE 6	マニホールドバルブ組 6連	1
9		SL-4043091-SC	SCREW M4 L=30	座金付きなべ小ねじ M4 L=30	4
10		HX-0033900-00	SPACER	スペーサ	12
11		SL-4040881-SC	SCREW M4 L=8	座金付きなべ小ねじ M4 L=8	12
12		PJ-3040651-01	ELBOW UNION 6XPT1/8	エルボユニオン 6XPT1/8	1
13		PJ-3080600-03	UNION Y	ユニオンワイ	1
14		PJ-3050600-04	T	チーズ	2
15		SL-4042091-SC	SCREW M4 L=20	座金付きなべ小ねじ M4 L=20	3
16		PJ-3080600-04	BRANCH UNION Y	ブランチユニオンワイ	1
17		PV-2051010-00	SHUTTLE VALVE	シャトルバルブ	1
18		SL-4052591-SC	SCREW M5 L=25	座金付きなべ小ねじ M5 L=25	1
19		PJ-3010651-03	HALF UNION 6XPT1/8	ハーフユニオン 6XPT1/8	3
20		PC-0205010-A0	MINIATURE DECOMPRESSION VALVE	ミニチュア減圧弁	2
21		SL-4051091-SC	SCREW M5 L=10	座金付きなべ小ねじ M5 L=10	4
22		PJ-3040405-04	UNION	ユニオン	2
23		PJ-3040605-02	ELBOW UNION 6XM5	エルボユニオン 6XM5	2
24		PV-1502130-00	5-PORT SOLENOID VALVE	5ポート電磁弁	1
25		SL-4041091-SC	SCREW M4 L=10	座金付きなべ小ねじ M4 L=10	2
26		PJ-3010652-01	HALF UNION 6XPT1/4	ハーフユニオン 6XPT1/4	1
27		PX-0551040-00	SILENCER	サイレンサ	2
28		PV-1502140-00	5-PORT SOLENOID VALVE	5ポート電磁弁	1
29		SL-4041091-SC	SCREW M4 L=10	座金付きなべ小ねじ M4 L=10	2
30		PJ-3040652-01	ELBOW UNION 6XPT1/4	エルボユニオン 6XPT1/4	1
31		PJ-3010652-01	HALF UNION 6XPT1/4	ハーフユニオン 6XPT1/4	2
32		PX-0551040-00	SILENCER	サイレンサ	2
33		PV-1502150-00	5-PORT SOLENOID VALVE	5ポート電磁弁	1
34		SL-4031091-SC	SCREW M3 L=10	座金付きなべ小ねじ M3 L=10	2
35		PJ-3040605-02	ELBOW UNION 6XM5	エルボユニオン 6XM5	3
36		PX-0505010-00	SILENCER	消音器	2
37		PV-1306001-00	3-PORT SOLENOID VALVE	3ポート電磁弁	4
38		SL-4030891-SC	SCREW M3 L=8	座金付きなべ小ねじ M3 L=8	8
39		PJ-3010605-03	HALF UNION	ハーフユニオン	1
40		PJ-3040405-05	UNION	ユニオン	3
41		PX-0505010-00	SILENCER	消音器	4
42		401-16209	ASSY MANIFOLD VALVE SPPORT PLATE	マニホールドバルブ組サポートプレート	1
43		SL-6061492-TN	SCREW M6 L=14	座金付き六角穴ボルト M6 L=14	2
44		401-16208	ASSY MANIFOLD VALVE 6	マニホールドバルブ組 6連	1
45		SL-4043091-SC	SCREW M4 L=30	座金付きなべ小ねじ M4 L=30	4
46		PJ-3040651-01	ELBOW UNION 8XPT1/8	エルボユニオン 8XPT1/8	1
47		HX-0031400-00	SPIRAL TUBE	スパイラルチューブ	1
48		HX-0031400-0A	SPIRAL TUBE	スパイラルチューブ	3
49		HX-0031400-0B	SPIRAL TUBE	スパイラルチューブ	7
50		PJ-3080600-04	BRANCH UNION Y	ブランチユニオンワイ	1
51		PJ-3080800-03	DIFFERENT DIAMETER UNION Y	異径ユニオンワイ	1
52		401-16210	FILTER INSTALLING PLATE	フィルター取付け板	1
53		SL-6061492-TN	SCREW M6 L=14	座金付き六角穴ボルト M6 L=14	2
54		400-88208	FILTER REGULATOR ASSY	フィルターレギュレータ組	1
55		SM-4050801-SC	SCREW M5X0.8 L=8	なべ小ねじ M5 X 0.8 L=8	2
56		PJ-3080852-02	BRANCH Y	ブランチワイ	1
57		PJ-3080800-04	DIFFERENT DIAMETER BRANCH UNION Y	異径ブランチユニオンワイ	1
58		PJ-3030600-01	STRAIGHT UNION 6	ストレートユニオン 6	1
59		BT-0800501-EB	URETHANE TUBE BLACK 8X5	ポリウレタンチューブ 黒 8 X 5	3
60		BT-0600401-EB	URETHANE TUBE BLACK 6X4	ポリウレタンチューブ 黒 6 X 4	37.7
61		BT-0400251-EB	URETHANE TUBE BLACK 4X2.5	ポリウレタンチューブ 黒 4 X 2.5	111
62		401-16211	INT BOAD COVER A	INT ボードカバー A	1
63		SL-4041091-SC	SCREW M4 L=10	座金付きなべ小ねじ M4 L=10	6
64		401-16212	INT BOAD COVER B	INT ボードカバー B	1
65		SL-4041091-SC	SCREW M4 L=10	座金付きなべ小ねじ M4 L=10	4
66		401-16213	INT BOAD COVER C	INT ボードカバー C	1
67		SL-4031091-SC	SCREW M3 L=10	座金付きなべ小ねじ M3 L=10	3

25. BOBBIN WINDER COMPONENTS

糸巻装置関係

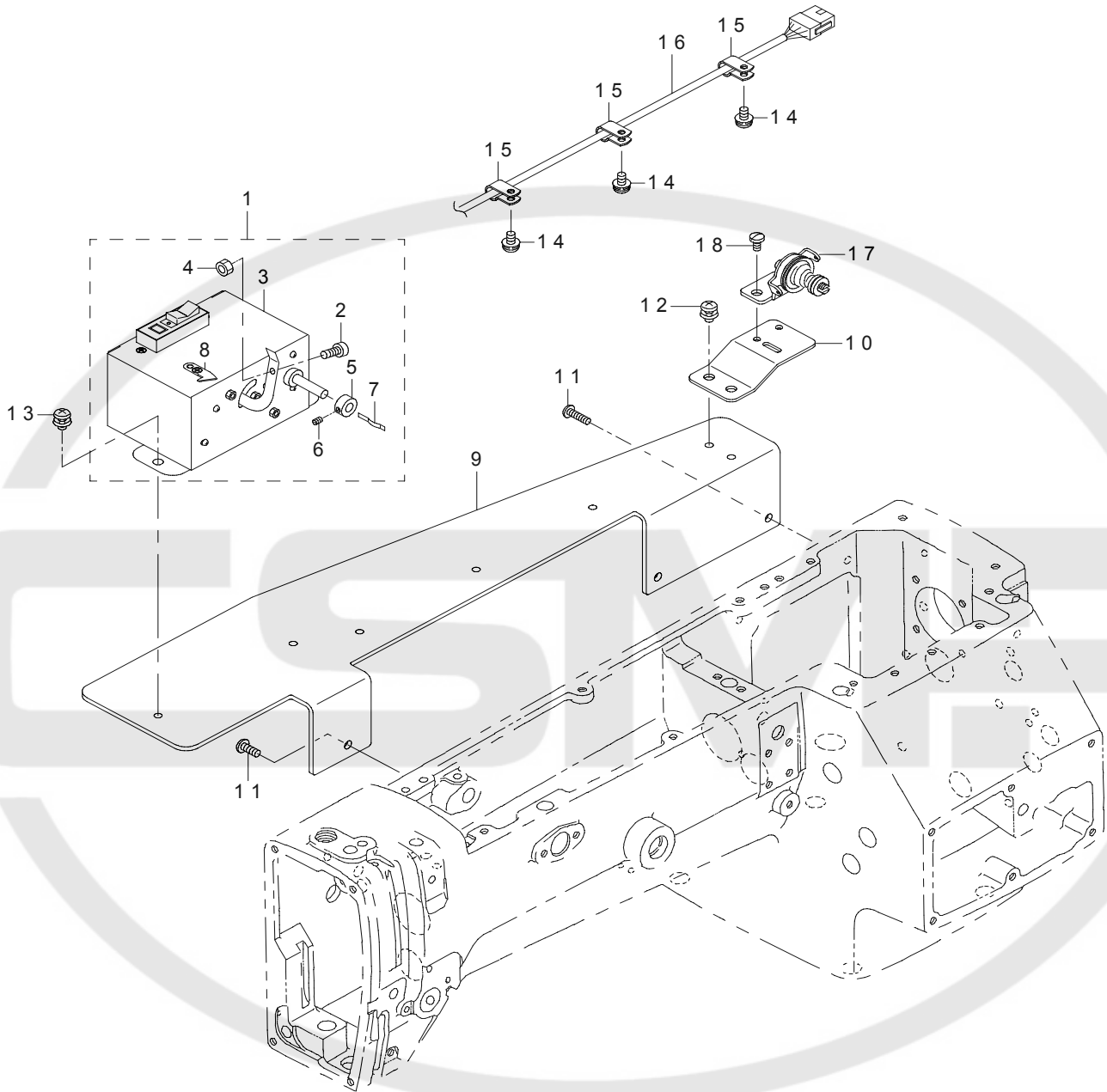

REF.NO	NOTE	PART NO	DESCRIPTION	品名	Qty
1		G8031-875-0A0	BOBBIN WINDER ASM.	糸巻装置 (組)	1
2		G8031-875-000	BOBBIN PRESSER BOSS	ボビン押えボス	(1)
3		138-70258	BOBBIN THREAD WIDING DEVICE	糸巻装置 (結合)	(1)
4		NS-6110420-SP	NUT 11/64-40	六角ナット 11/64-40	(1)
5		CS-0640611-SP	THRUST HOLDER	スラスト受	(1)
6		SS-8090530-TP	SCREW 9/64-40 L=5.0	止めねじ 9/64-40 L=5	(1)
7		B3212-761-000	LATCH SPRING	ボビン止めばね	(1)
8		105-02300	THREAD CUTTER	糸切保持板	(1)
9		G8033-875-000	BOBBIN DEVICE FITTING PLATE	糸巻装置取付板	1
10		G3216-270-000	BOBBIN BASE	糸巻台	1
11		SS-4121615-SP	SCREW 3/16-28 L=16	なべねじ 3/16-28 L=16	3
12		SL-4051091-SC	SCREW M5X0.8 L=10	なべ小ねじセムス M5X0.8 L=10	2
13		SL-4051091-SC	SCREW M5X0.8 L=10	なべ小ねじセムス M5X0.8 L=10	2
14		SL-4051091-SC	SCREW M5X0.8 L=10	なべ小ねじセムス M5X0.8 L=10	3
15		HX-0015000-0C	CABLE CLIP	束線パーツ	3
16		G8032-875-0A0	BOBBIN POWER SOURCE CORD ASM.	糸巻電源コード組	1
17		138-89951	BOBBIN GUIDE ASM.	糸巻案内 (組)	1
18		SS-7110840-SP	SCREW 11/64-40 L=7.8	丸平ねじ 11/64-40 L=7.8	2



26. STACKER COMPONENTS

スタッカー関係

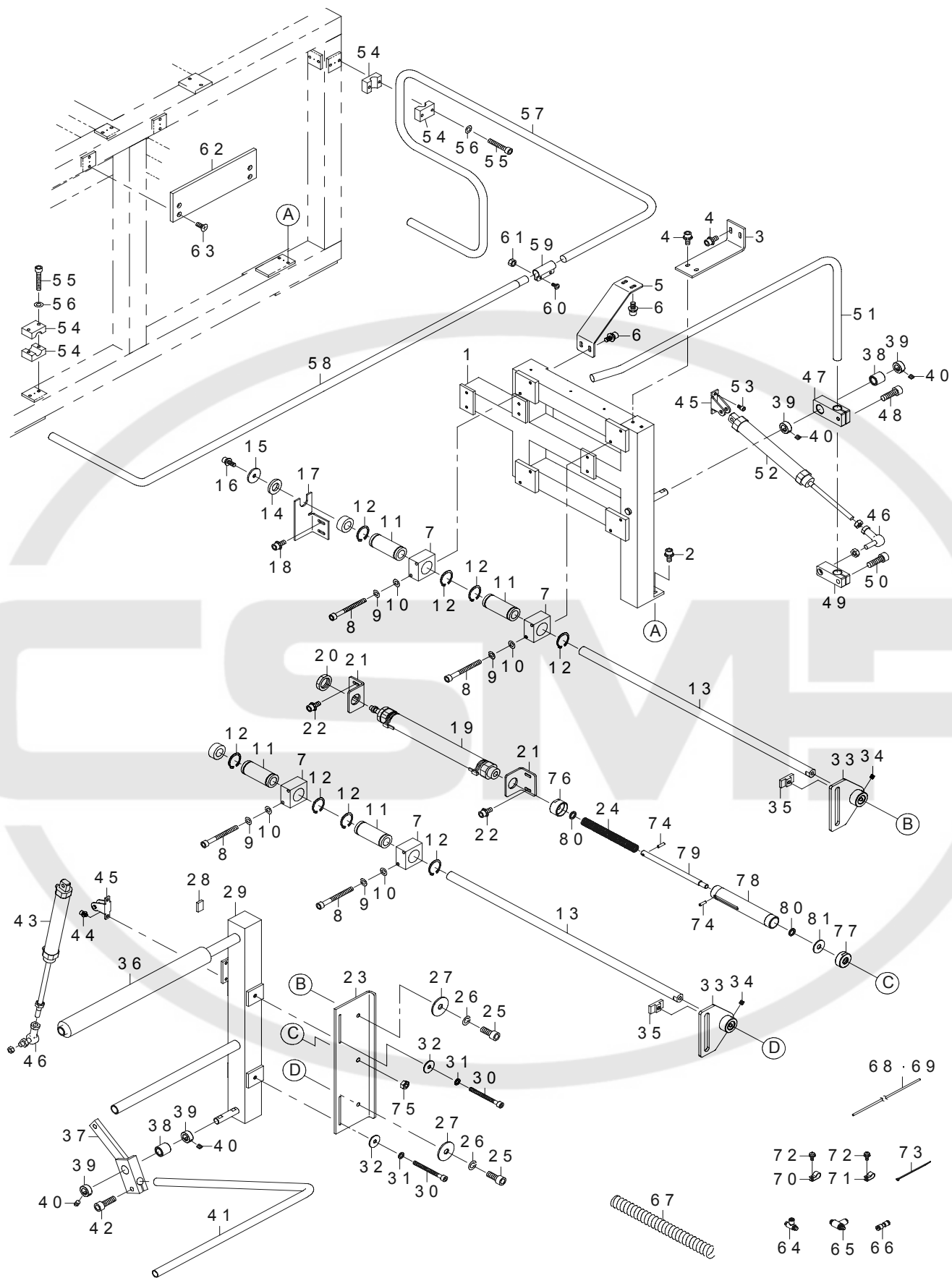

REF.NO	NOTE	PART NO	DESCRIPTION	品名	Qty
1		401-16178	STACKER BASE ASSY	スタッカーベース	1
2		SL-6061492-TN	SCREW M6 L=14	座金付き六角穴ボルト M6 L=14	2
3		401-16179	FITTING PLATE A	プレートA	1
4		SL-6061492-TN	SCREW M6 L=14	座金付き六角穴ボルト M6 L=14	4
5		401-16180	FITTING PLATE B	プレートB	1
6		SL-6061492-TN	SCREW M6 L=14	座金付き六角穴ボルト M6 L=14	4
7		401-16181	SLIDER SHAFT BLOCK	スライダシャフトブロック	4
8		SM-6066052-TP	SCREW M6 L=60	六角穴ボルト M6 L=60	8
9		WS-0610002-KN	SPRING WASHER M6	ばね座金 M6	8
10		WP-0641601-SC	WASHER M6	平座金みがき丸 M6	8
11		401-16182	SLIDER SHAFT BUSHING	スライダシャフトブッシュ	4
12		RC-3781518-KP	C-RING 35 (30)	C形止め輪 35 (30)	8
13		401-16183	SLODER SHAFT	スライドシャフト	2
14		401-16184	STOPPER RUBBER	ストッパーラバー	1
15		400-74011	CHUCK PLATE	チャック板	1
16		SL-6082092-TN	SCREW M8 L=20	座金付き六角穴ボルト M8 L=20	1
17		401-16185	STOPPER PLATE	ストッパープレート	1
18		SL-6061492-TN	SCREW M6 L=14	座金付き六角穴ボルト M6 L=14	2
19		401-05074	FRONT BEHIND CYLINDER ASSY	スタッカ前後シリンダー組	1
20		NM-6260810-SC	NUT M26	六角ナット M26	1
21		401-16186	SLIDER CYLINDER BASE PLATE	シリンダ取付板	2
22		SL-6061492-TN	SCREW M6 L=14	座金付き六角穴ボルト M6 L=14	4
23		401-16187	CLOTH FEED TUBE JOINT	取付板	1
24		401-16202	SPRING	スプリング	1
25		SM-6082002-TP	SCREW M8 L=20	六角穴ボルト M8 L=20	2
26		WS-0822010-KP	SPRING WASHER 8.2X15X2	ばね座金 8.2 X 15 X 2	2
27		WP-0852086-SC	WASHER M8	平座金	2
28		400-39896	CUSHION	クッション	3
29		401-16188	STAND TUBE ASSY	スタンド組	1
30		SM-6088502-TP	SCREW M8 L=85	六角穴ボルト M8 L=85	2
31		WS-0861410-KR	SPRING WASHER 8.6X15X1.4	ばね座金 8.6 X 15 X 1.4	2
32		WP-0852086-SC	WASHER M8	平座金	2
33		401-16519	CLOTH FEED TUBE JOINT A	クロスフィードチューブジョイントA	2
34		SM-8080812-TP	SCREW M8X8	止めねじ M8 L=8	4
35		401-16518	SCREW STOPPER	スクリューストッパー	2
36		400-35143	CLAMP BASE CUSHION	クランプベーススタッカー	1
37		401-16189	CLAMP BAR BASE	クランプバーベース	1
38		400-35147	METAL	クランプベーススタッカー	2
39		CS-1501171-TP	THRUST COLLAR D=15 W=11	スラスト受 D=15 W=11	4
40		SM-8060602-TP	SCREW M6X6	止めねじ M6 L=6	8
41		401-16190	CLAMP BAR	クランプバー	1
42		SM-6082502-TP	SCREW M8 L=25	六角穴ボルト M8 L=25	1
43		401-05075	STACKER FULL CYLINDER ASSY	スタッカフルシリンダー組	1
44		SL-6061042-TN	SCREW M6 L=10	座金付き六角穴ボルト M6 L=10	2
45		PA-9000600-00	CLEVIS HOLDER	クレビス受け	2
46		G6118-870-000	SHAPE REMOVING BALL	型移動リンクボール	2
47		401-16191	BRUSH BAR ROD	払いバー土台	1
48		SM-6082502-TP	SCREW M8 L=25	六角穴ボルト M8 L=25	1
49		401-16192	BRUSH BAR BRACKET	払いバーブラケット	1
50		SM-6082502-TP	SCREW M8 L=25	六角穴ボルト M8 L=25	1
51		401-16193	CLOYH BRUSH BAR	布払いバー	1
52		401-05076	DRIVE AWAY CYLINDER ASSY	布払いシリンダー組	1
53		SM-6061002-TP	SCREW M6 L=10	六角穴ボルト M6 L=10	2
54		G7524-870-000	PIPE CLAMP MAIN BODY	パイプクランプ本体	4
55		SM-6063502-TN	HEXAGONAL-HOLE BOLT M6 L=35	六角穴ボルト M6 L=35	4
56		WP-0641600-SC	WASHEW 6.4X12.5X1.6	平座金	4
57		401-16194	SAFTY BAR A	安全バー A	1
58		401-16195	SAFTY BAR B	安全バー B	1
59		229-31307	SPOOL REST ROD JOINT	糸立棒継手	1
60		SM-4051001-SN	SCREW M5	なべ小ねじ M5 X 0.8 L=10	2
61		NM-6050001-SE	NUT M5X0.8 TYPE1	六角ナット M5 X 0.8 1種	2
62		401-16196	CLOTHES STOPPER	ストッパー	1
63		SM-1061401-SE	SCREW M6 L=14	皿小ねじ M6 L=14	4
64		PC-0151080-00	SPEED CONTROLLER	スピードコントローラ	4
65		PC-0151060-00	SPEED CONTROLLER	スピードコントローラ	2
66		PJ-3030400-02	STRAIGHT UNION 4	ストレートユニオン4	2
67		G5611-341-000	SPIRAL TUBE	スパイラルチューブ	1
68		BT-0400251-EB	URETHANE TUBE BLACK 4X2.5	ポリウレタンチューブ黒 4 X 2.5	7
69		BT-0600401-EB	URETHANE TUBE BLACK 6X4	ポリウレタンチューブ黒 6 X 4	3
70		HX-0015000-0E	CABLE CLAMP	ケーブルクリップ	14
71		HX-0015000-0D	CABLE CLAMP	ケーブルクリップ	12
72		SL-4041091-SC	SCREW M4 L=10	座金付きなべ小ねじ M4 L=10	26
73		EA-9500B01-00	CABLE BAND	束線バンド	10
74		401-16197	PIN	ピン	2
75		NM-6100001-SC	NUT M10X1.5 TYPE1	六角ナット M10 X 1.5 1種	1
76		401-16198	HOUSING CAP A	キャップA	1
77		401-16199	HOUSING CAP B	キャップB	1
78		401-16200	HOUSING PIPE	パイプ	1
79		401-16201	GUIDE SHAFT	ガイドシャフト	1
80		WP-1221016-SP	WASHER	平座金	2
81		GAK-33032000	SOLENOID RUBBER	ソレノイドゴムB	1

27. CREASE GAGE COMPONENTS

折りゲージ関係

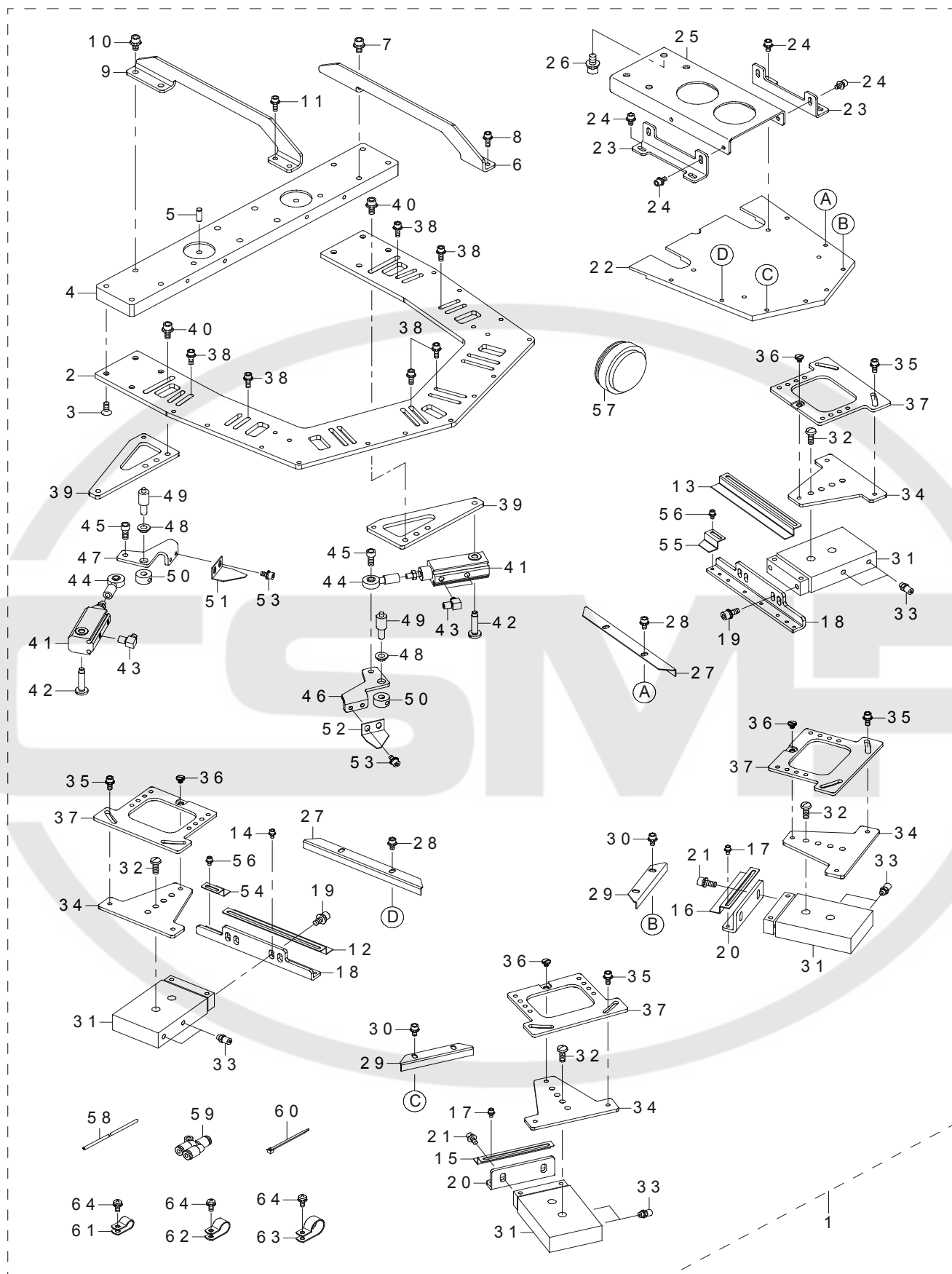

REF.NO	NOTE	PART NO	DESCRIPTION	品名	Qty
1		401-16545	PH CREASE GAGE COMPONENTS	折りゲージ	1
2		401-16464	FOLDING BASE PLATE(L)	折り込みベース板 (L)	(1)
3		SM-1051201-SC	SCREW M5X0.8 L=12	皿小ねじ M 5 X 0. 8 L = 1 2	(8)
4		401-16465	FOLDING BASE FITTING PLATE	折り込みベース取付け板	(1)
5		G6017-875-000	GAUGE PIN	折り位置決めピン	(2)
6		401-16466	FOLDING BASE SUPPORT PLATE RIGHT	折り込みベース補強板右	(1)
7		SL-6051092-TN	SCREW M5 L=10	座金付き六角穴ボルト M 5 L = 1 0	(2)
8		SL-6041292-TN	SCREW M4 L=12	座金付き六角穴ボルト M 4 L = 1 2	(2)
9		401-16467	FOLDING BASE SUPPORT PLATE LEFT	折り込みベース補強板左	(1)
10		SL-6051092-TN	SCREW M5 L=10	座金付き六角穴ボルト M 5 L = 1 0	(2)
11		SL-6041292-TN	SCREW M4 L=12	座金付き六角穴ボルト M 4 L = 1 2	(2)
12		401-16468	FOLDING PLATE A LEFT	折り込み板 A 左	(1)
13		401-16469	FOLDING PLATE A RIGHT	折り込み板 A 右	(1)
14		SL-6030692-TN	SCREW M3 L=6	座金付き六角穴ボルト M 3 L = 6	(6)
15		401-16470	FOLDING PLATE B LEFT	折り込み板 B 左	(1)
16		401-16471	FOLDING PLATE B RIGHT	折り込み板 B 右	(1)
17		SL-6030692-TN	SCREW M3 L=6	座金付き六角穴ボルト M 3 L = 6	(4)
18		401-16472	FOLDING SUPPORT PLATE A	布押え板 A	(2)
19		SL-6051292-TN	SCREW M5 L=12	座金付き六角穴ボルト M 5 L = 1 2	(4)
20		401-16473	FOLDING SUPPORT PLATE B	布押え板 B	(2)
21		SL-6051292-TN	SCREW M5 L=12	座金付き六角穴ボルト M 5 L = 1 2	(4)
22		401-16474	POCKET PRESSER PLATE (M SIZE)	ポケット押え板	(1)
23		401-16475	POCKET PRESSER POSITIONING PLATE	ポケット押え位置決め板	(2)
24		SL-6040892-TN	SCREW M4 L=8	座金付き六角穴ボルト M 4 L = 8	(8)
25		401-16476	POCKET PRESSER FITTING PLATE	ポケット押え取付け板	(1)
26		SL-6061492-TN	SCREW M6 L=14	座金付き六角穴ボルト M 6 L = 1 4	(4)
27		401-16477	VERTICAL FOLDING PLATE A	ポケット縦折り板 A	(2)
28		SL-6040892-TN	SCREW M4 L=8	座金付き六角穴ボルト M 4 L = 8	(4)
29		401-16478	VERTICAL FOLDING PLATE B	ポケット縦折り板 B	(2)
30		SL-6040892-TN	SCREW M4 L=8	座金付き六角穴ボルト M 4 L = 8	(4)
31		PA-1502008-A0	AIR CYLINDER	エアシリンダ	(4)
32		SM-5051400-SC	SCREW M5 L=14	トラスねじ M 5 X 0. 8 L = 1 4	(8)
33		PJ-0320525-03	HOSE NIPPLE	ホースニップル	(8)
34		401-16480	ROTABLE CYLINDER PLATE	折り込みシリンダ一回転取付け板	(4)
35		SL-6041092-TN	SCREW M4 L=10	座金付き六角穴ボルト M 4 L = 1 0	(8)
36		SD-0500166-TP	SHOULDER SCREW D=5 H=1.6	段ねじ D = 5 H = 1. 6	(4)
37		401-16481	MOVABLE CYLINDER PLATE	折り込みシリンダ移動取付け板	(4)
38		SL-6041292-TN	SCREW M4 L=12	座金付き六角穴ボルト M 4 L = 1 2	(16)
39		401-16482	POCKET MOUTH FOLD BASE	口折り取付台	(2)
40		SL-6051292-TN	SCREW M5 L=12	座金付き六角穴ボルト M 5 L = 1 2	(4)
41		PA-1602014-A0	AIR CYLINDER	エアシリンダ	(2)
42		401-16483	FOLDING STEP SCREW	口折りシリンダ支点段ねじ	(2)
43		PJ-0460525-03	HOSE ELBOW	ホースエルボ	(4)
44		B1632-180-000	FEED ADJUSTING JOINT	送り調節ジョイント	(2)
45		SM-6051202-TP	SCREW M5X0.8 L=12	六角穴ボルト M 5 X 0. 8 L = 1 2	(2)
46		401-16484	FOLDING PLATE RIGHT	口折り駆動右	(1)
47		401-16485	FOLDING PLATE LEFT	口折り駆動左	(1)
48		G6031-870-000	BEARING	口折りベアリング	(2)
49		401-16486	POCKET MOUTH FOLD SHAFT A	口折り軸 A	(2)
50		G6014-880-000	LINK THRUST HOLDER	リンクスラスト受け	(2)
51		G6015-875-000	CREASING PLATE	口折り板左	(1)
52		G6016-875-000	CREASING PLATE	口折り板右	(1)
53		SL-6040892-TN	SCREW M4 L=8	座金付き六角穴ボルト M 4 L = 8	(4)
54		401-16487	CREASING PLATE LEFT	折り込み板 (口部) (左)	(1)
55		401-16488	CREASING PLATE RIGHT	折り込み板 (口部) (右)	(1)
56		SL-6030692-TN	SCREW M3 L=6	座金付き六角穴ボルト M 3 L = 6	(4)
57		PJ-4010004-00	MULTI CONNECTOR (PLUG)	マルチコネクタ (プラグ側)	(1)
58		BT-0400251-EB	URETHANE TUBE BLACK 4X2.5	ポリウレタンチューブ 黒 4 X 2. 5	(1)
59		PJ-3080400-02	QUICK JOINT	ワンタッチ継手	(2)
60		HX-0023300-00	CABLE BAND	束線バンド	(12)
61		HX-0015000-0C	CABLE CLAMP	ケーブルクリップ	(4)
62		HX-0015000-0E	CABLE CLAMP	ケーブルクリップ	(8)
63		HX-0015000-0H	CABLE CLAMP	ケーブルクリップ	(1)
64		SL-4041091-SC	SCREW M4 L=10	座金付きなべ小ねじ M 4 L = 1 0	(13)

28. FORM PLATE GAGE COMPONENTS

型板ゲージ関係

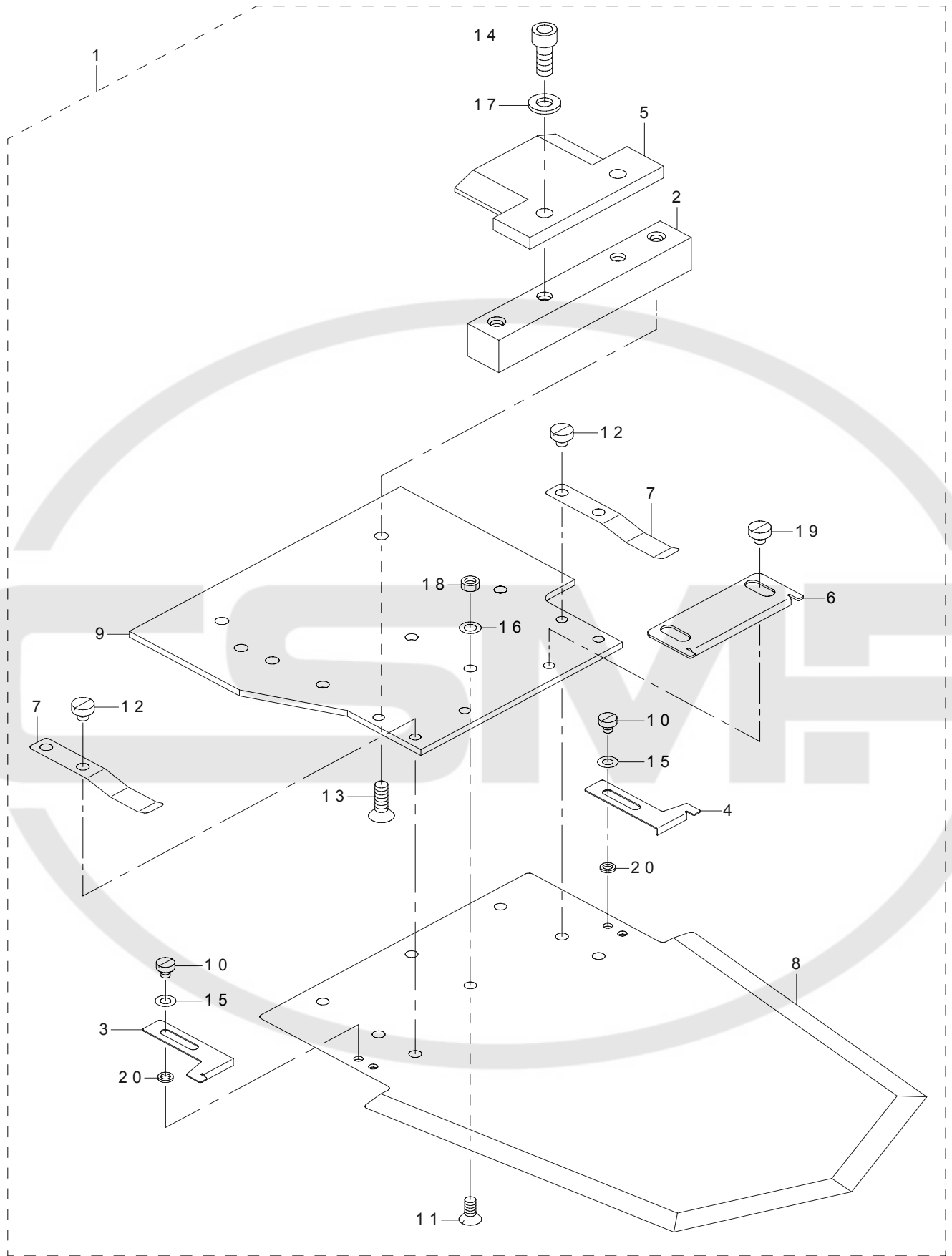

REF.NO	NOTE	PART NO	DESCRIPTION	品名	Qty
1		401-16546	PH FORM PLATE GAGE COMPONENTS	型板ゲージ	1
2		G6110-875-000	LOCATING PLATE	型板位置出し板	(1)
3		G6115-875-000	LOCATING PLATE	位置出し板左	(1)
4		G6116-875-000	LOCATING PLATE	位置出し板右	(1)
5		G6019-870-000	ONE TOUCH LOCK PLATE	ワンタッチロック板	(1)
6		G6114-875-000	POCKET CLOTH LOCATING PLATE A	ボケ布位置決め板 A	(1)
7		G6111-870-000	POCKET PRESSER SPRING	ポケット押えばね	(2)
8		401-16489	TEMPLATE	型板	(1)
9		401-16490	TEMPLATE FITTING PLATE	型板取付板	(1)
10		SS-6090420-SP	SCREW 9/64-40 L= 4.0	平ねじ 9/64-40 L=4	(4)
11		SS-2111010-TP	SCREW 11/64-40 L=9.5	丸皿ねじ 11/64-40 L=9.5	(4)
12		SS-6110480-SP	SCREW 11/64-40 L=4.3	平ねじ 11/64-40 L=4.3	(4)
13		SM-1051601-SC	SCREW M5X0.8 L=16	皿小ねじ M5 X 0.8 L=16	(2)
14		SM-6061602-TN	SCREW M6 L=16	六角穴ボルト M6 L=16	(2)
15		WP-0410846-SC	WASHER	平座金	(4)
16		WP-0480856-SP	WASHER 4.8X8.4X0.8	平座金 4.8 X 8.4 X 0.8	(4)
17		WP-0641601-SC	WASHER M6	平座金みがき丸 M6	(2)
18		NS-6110360-SP	HEXAGONAL NUT 11/64-40	六角ナット 11/64-40	(4)
19		SS-6110480-SP	SCREW 11/64-40 L=4.3	平ねじ 11/64-40 L=4.3	(2)
20		WP-0371036-SD	WASHER 3.7X6X1	平座金 3.7 X 6 X 1	(4)

CSMP

29. PRESSER GAGE COMPONENTS

押えゲージ関係

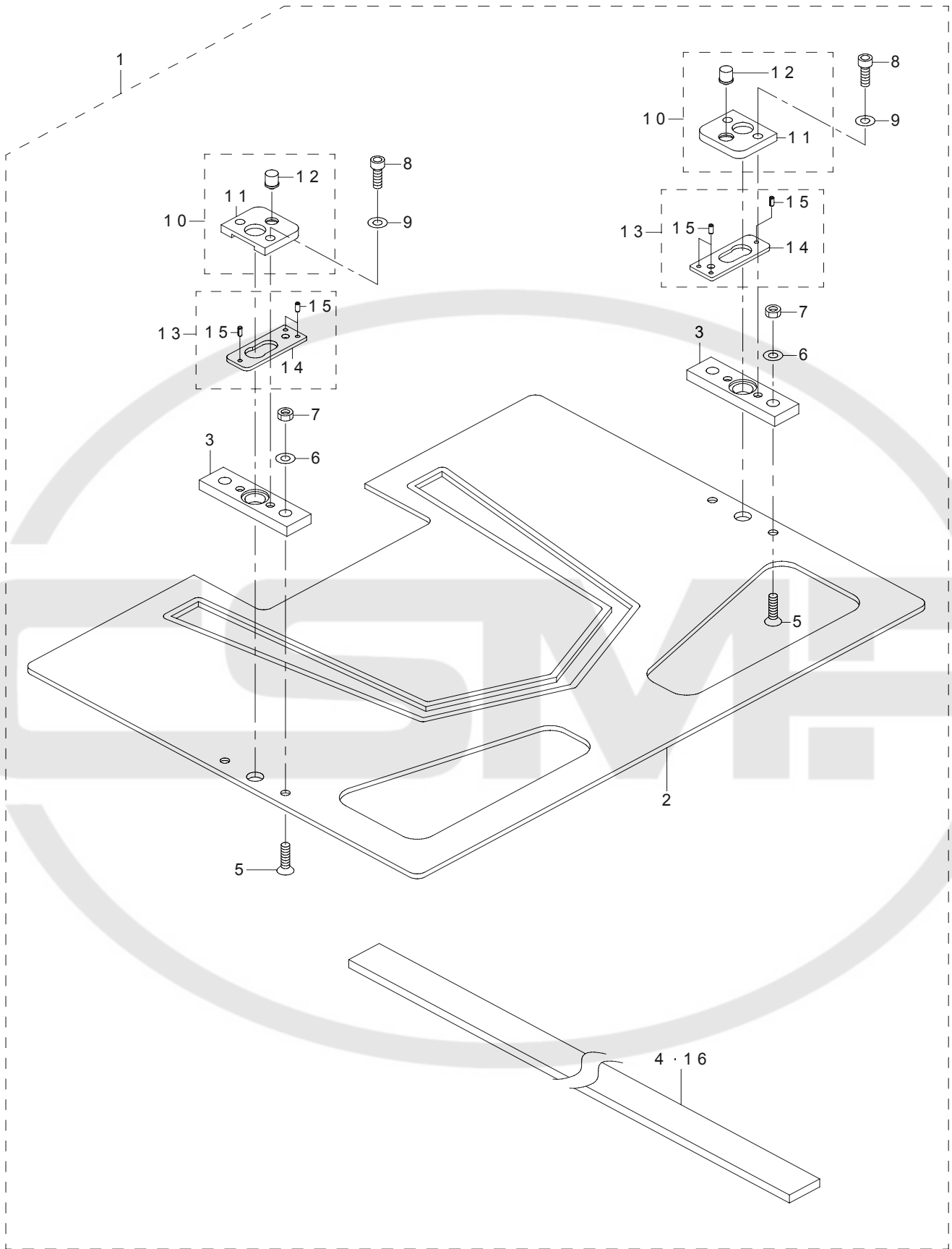

REF.NO	NOTE	PART NO	DESCRIPTION	品名	Qty
1		401-16547	PH PRESSER GAGE COMPONENTS	押えゲージ	1
2		401-16491	PRESSER PLATE (SPECIAL)	押え板	(1)
3		G6112-875-000	BALL CATCH	ボールキャッチ	(2)
4		G6113-875-000	CLOTH PRESSER SPONGE	布押えスポンジ	(1)
5		SM-1041601-SC	SCREW M4X0.7 L=16	皿小ねじ M 4 X 0. 7 L = 1 6	(4)
6		WP-0430801-SC	WASHER M4	平座金 M 4	(4)
7		NM-6040001-SC	NUT M4X0.7 TYPE1	六角ナット M 4 X -0. 7 1種	(4)
8		SM-6041002-TN	SCREW	六角穴ボルト	(4)
9		WP-0430801-SC	WASHER M4	平座金 M 4	(4)
10		G6119-875-0A0	BALL SUPPORT FIXING PLATE ASM.	ボール支え固定板組	(2)
11		G6119-875-000-A	BALL SUPPORT FIXING PLATE	ボール支え固定板	(1)
12		G6122-875-000	BALL SUPPORT PLUNGER	ボール支えプランジャ	(1)
13		G6120-875-0A0	BALL SUPPORT ASM.	ボール支え組	(2)
14		G6120-875-000-A	BALL SUPPORT	ボール支え	(1)
15		PS-0200052-KH	SPRING PIN 2X5	スプリングピン 2 X 5	(3)
16		G6113-875-00A	CLOTH PRESSER SPONGE A	布押えスポンジ A	(1)



30. OPERATION PANEL COMPONENTS

操作パネル関係

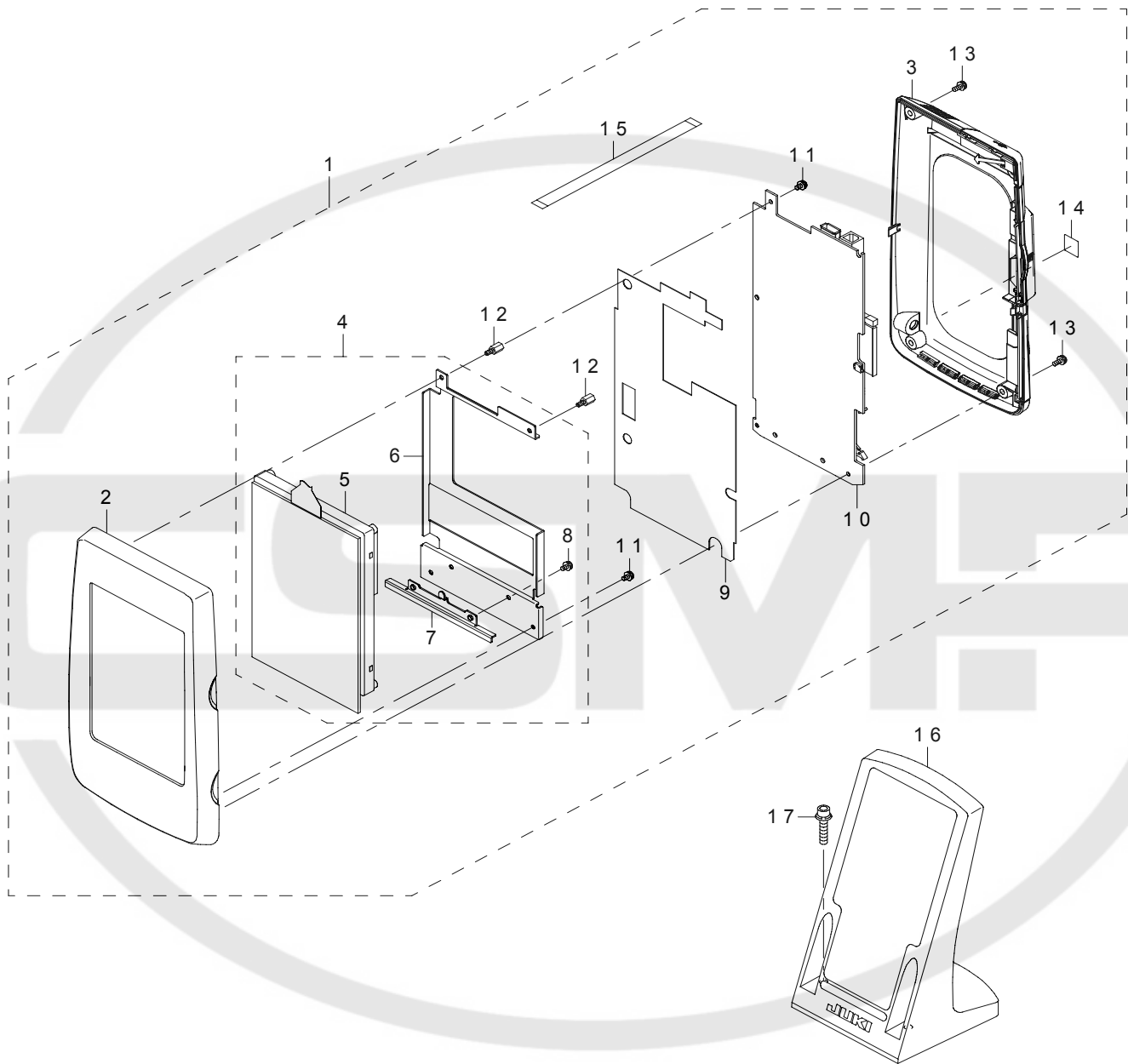

REF.NO	NOTE	PART NO	DESCRIPTION	品 名	Qty
1		401-05020	IP-420 TYPE K	IP-420K組	1
2		400-78163	FRONT CASE	前面ケース	(1)
3		400-80799	REAR CASE ASSY	リアパネル組	(1)
4		400-80800	LCD ASSY	LCD組	(1)
5		400-86541	LCD TOUCH PANEL ASSY	LCDタッチパネル組	(1)
6		400-83668	LCD BRACKET	LCDブラケット	(1)
7		400-83666	LCD STAY	LCD支え板	(1)
8		SL-4030681-SC	SCREW M3 L=6	座金付きなべ小ねじ M3 L=6	(2)
9		400-78168	INSULATION SHEET	絶縁シート	(1)
10		400-83960	PANEL PCB ASSY	パネル基板組	(1)
11		SL-4030681-SC	SCREW M3 L=6	座金付きなべ小ねじ M3 L=6	(3)
12		HX-0035400-0B	SPACER	スペーサ	(2)
13		SL-4030881-SC	SCREW M3X8	なべ小ねじセムス M3 X 0.5 L=8	(4)
14		CM-6001001-01	WEEE MARK LABEL S	WEEEマークラベルS	(1)
15		HW-0021802-00	FLAT CABLE	フラットケーブル	(1)
16		400-35024	OPERATION BOX FIXED PLATE(B)ASM.	操作箱取付け板(B)組	1
17		SL-6052592-TN	SCREW M5 L=25	座金付き六角穴ボルト M5 L=25	2



31. CONTROL BOX COMPONENTS

電装ボックス関係

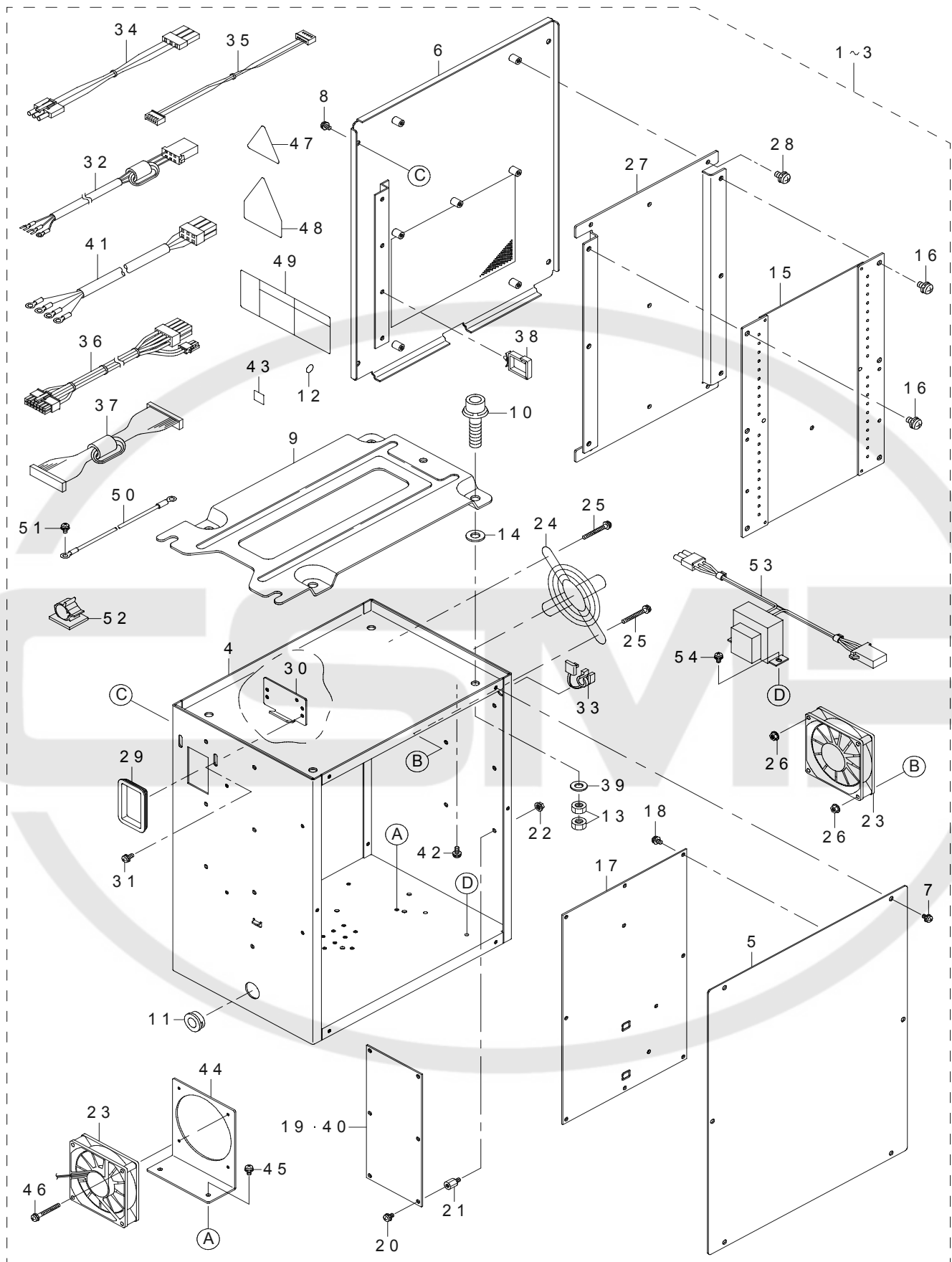

REF.NO	NOTE	PART NO	DESCRIPTION	品名	Qty
1	#01	401-05004	CONTROL BOX A ASM.	電装ボックス A 組	1
2	#02	401-05005	CONTROL BOX B ASM.	電装ボックス B 組	1
3	#03	401-05006	CONTROL BOX C ASM.	電装ボックス C 組	1
4		400-55355	CONTROL BOX	電装ボックス	(1)
5		400-55356	CONTROL BOX FRONT COVER	電装ボックス前蓋	(1)
6		400-55357	CONTROL BOX REAR COVER	電装ボックス後ろ蓋	(1)
7		SL-4040891-SC	SCREW M4 L=8	座金付きなべ小ねじ M4 L=8	(6)
8		SL-4040891-SC	SCREW M4 L=8	座金付きなべ小ねじ M4 L=8	(4)
9		M3801-476-000	TRANSMISSION BOX FITTING PLATE	電装ボックス取付け板	(1)
10		SL-6083092-TN	SCREW	座金付き六角穴ボルト	(4)
11		HX-0032600-0K	GROMMET	束線パーツ	(1)
12		E9567-319-000	EARTH MARK	アースマーク	(1)
13		NM-6080001-SC	NUT M8X1.25	六角ナット M8 1種	(8)
14		M4206-461-000	WASHER	ゴム付き座金	(4)
15		401-05030	MAIN PCB ASSY	MAIN 基板組	(1)
16		SL-4040891-SC	SCREW M4X8	座金付きなべ小ねじ M4 L=8	(6)
17		400-82758	SDC PCB A ASSY	SDC 基板 A 組	(1)
18		SL-4040881-SC	SCREW M4 L=8	座金付きなべ小ねじ M4 L=8	(10)
19	#04	400-00046	FLT-S PCB A ASSY	FLT-S 基板 A 組	(1)
20		SL-4040881-SC	SCREW M4 L=8	座金付きなべ小ねじ M4 L=8	(6)
21		HX-0033900-00	STUD	基板パーツ	(6)
22		NM-3040520-SC	NUT M4	フランジ付きナット M4	(6)
23		400-05401	FAN MOTOR ASS'Y	ファンモータ組	(2)
24		KM-0000004-80	FAN MOTOR	フィンガーガード	(1)
25		SL-4043591-SC	SCREW	座金付きなべ小ねじ	(4)
26		NM-3040520-SC	NUT M4	フランジ付きナット M4	(4)
27		400-05706	MAIN PCB HOLDER PLATE	MAIN 基板止め板	(1)
28		SL-4040881-SC	SCREW M4 L=8	座金付きなべ小ねじ M4 L=8	(5)
29		HX-0040700-00	BUSH	ブッシュ	(1)
30		178-45009	CORD FITTING PLATE	コード止め板	(1)
31		SL-4041091-SC	SCREW M4 L=10	なべ小ねじセムス M4 X 0.7 L=10	(2)
32	#04	400-86466	POWER CORD JE ASSY	電装電源コード JE 組	(1)
33		KX-0000003-20	BUSH	ブッシュ	(1)
34	#01	400-05393	FLT-SDC CORD P ASS'Y	FLT-SDC コード P 組	(1)
35		400-05394	FLT-SDC CORD S ASS'Y	FLT-SDC コード S 組	(1)
36		401-05078	SDC-MAIN CORD P ASSY	SDC-MAIN コード P 組	(1)
37		400-82736	SDC-MAIN CORD S ASSY	SDC-MAIN コード S 組	(1)
38		HX-0051100-00	WIRE SADDLE	ワイヤサドル	(3)
39		WP-0841601-SC	WASHER 8.4X17.4X1.6	平座金みがき丸 M8	(4)
40	#03	400-51320	FLT-T PCB B ASSY	FLT-T 基板 B 組	(1)
41	#03	400-86465	POWER CORD 3P ASSY	電装電源コード 3P 組	(1)
42	#04	SL-4041091-SC	SCREW M4 L=10	座金付きなべ小ねじ M4 L=10	(1)
43		CM-6001001-01	WEEE MARK LABEL S	WEEE マークラベル S	(1)
44		400-05404	FAN MOTOR BRACKET	ファンモータブラケット	(1)
45		SL-4040891-SC	SCREW M4X8	座金付きなべ小ねじ M4 L=8	(2)
46		SL-4033091-SC	SCREW M3 L=30	座金付きなべ小ねじ M3 L=30	(4)
47	#04	CM-3001000-04	VOLTAGE WARNING LABEL (50)	危険電圧警告シール (50)	(1)
48		CM-3004006-01	VOLTAGE CAUTION LABEL L=63	電圧注意シール L=63	(1)
49	#03	CM-3001004-01	VOLTAGE DANGER LABEL 3 (LARGE)	電撃危険ラベル 3 (大)	(1)
50		M9029-580-0A0	FDD EARTH CORD ASM.	FDD アース線組	(1)
51		SL-4040891-SC	SCREW M4X8	座金付きなべ小ねじ M4 L=8	(4)
52		KX-0000003-30	WIRE SADDLE	ワイヤサドル	(1)
53	#05	400-90589	REACTOR	リアクター	(1)
54	#05	SL-4040881-SC	SCREW M4 L=8	座金付きなべ小ねじ M4 L=8	(2)
		NOTE(注記)	#01....FOR GENERAL EXPORT (1-PHASE 200~240V)	一般輸出 (単相 200~240 V) 用	
			#02....FOR CE (1-PHASE 220~240V)	CE (単相 220~240 V) 用	
			#03....FOR GENERAL EXPORT AND USE IN JAPAN (3-PHASE 200~240V)	一般輸出・日本 (3相 200~240 V) 用	
			#04....FOR GENERAL EXPORT (1-PHASE 200~240V), CE(1-PHASE 220~240V)	一般輸出 (単相 200~240 V), CE (単相 220~240 V) 用	
			#05....FOR GENERAL EXPORT AND USE IN JAPAN (3-PHASE 200~240V), CE(1-PHASE 220~240V)	一般輸出・日本 (3相 200~240 V), CE (単相 220~240 V) 用	

32. WIRING DIAGRAM (1)

電装配線図 (1)

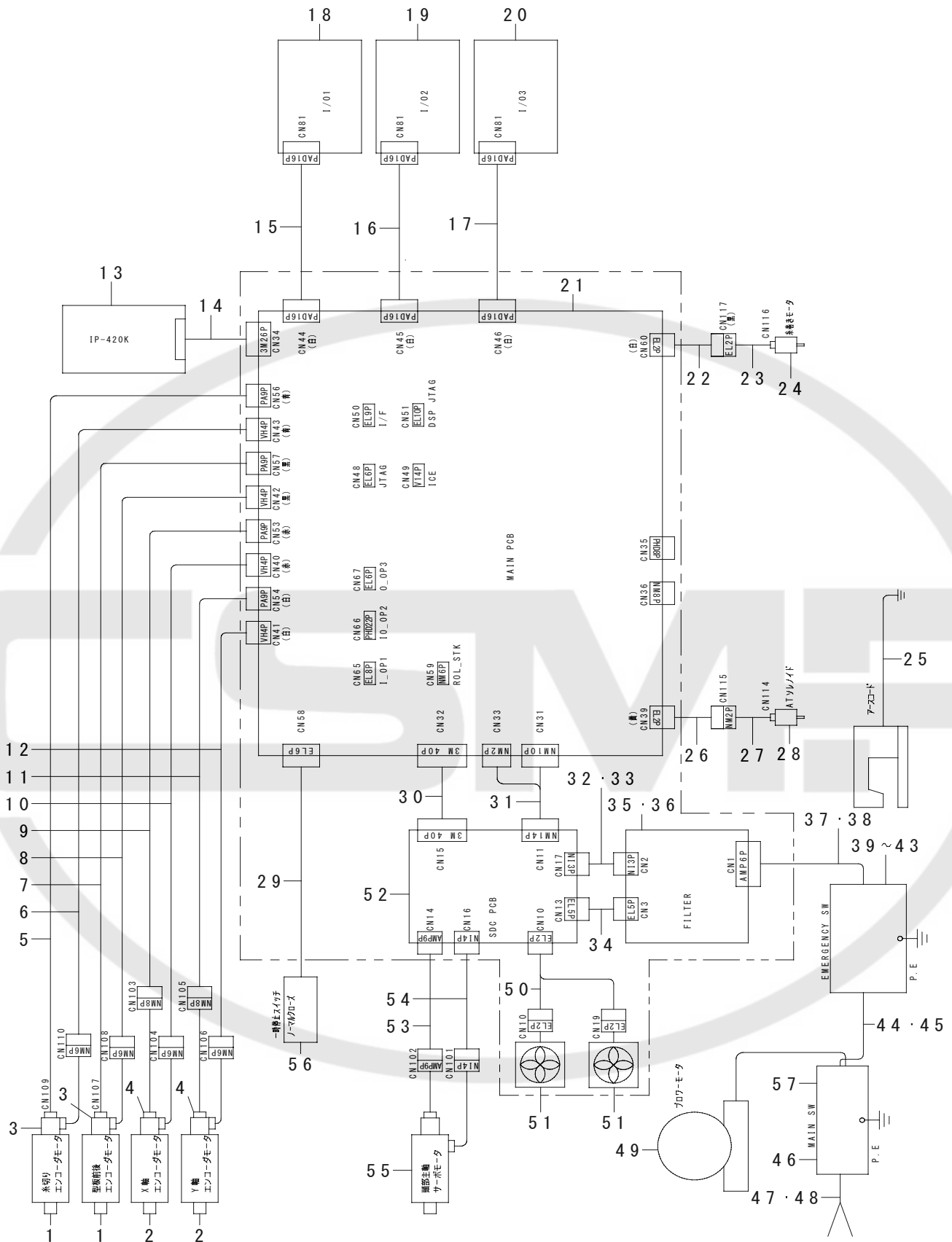

REF.NO	NOTE	PART NO	DESCRIPTION	品名	Qty
1		400-71944	STEPPING MOTOR	ステッピングモータ	2
2		401-05099	STEPPING MOTOR	ステッピングモータ	2
3		HD-0027800-00	SENSOR	センサー	2
4		401-05098	ENCODER ASSY	エンコーダ組	2
5		401-05101	TRM ENCODER CABLE ASSY	糸切りエンコーダケーブル組	1
6		401-05100	TRM MOTOR CABLE ASSY	糸切りモータケーブル組	1
7		401-05124	K ENCODER CABLE ASSY	型板前後エンコーダケーブル組	1
8		401-05122	K MOTOR CABLE ASSY	型板前後モータケーブル組	1
9		401-05105	X ENCODER CABLE ASSY	X 軸エンコーダケーブル組	1
10		401-05104	X MOTOR CABLE ASSY	X 軸モータケーブル組	1
11		401-05107	Y ENCODER CABLE ASSY	Y 軸エンコーダケーブル組	1
12		401-05106	Y MOTOR CABLE ASSY	Y 軸モータケーブル組	1
13		401-05020	IP-420 TYPE K	IP-420 K 組	1
14		400-73679	PANEL CABLE ASSY L	パネルケーブル組 L	1
15		401-05110	IO1 PCB CABLE ASSY	IO 1 基板ケーブル組	1
16		401-05112	IO2 PCB CABLE ASSY	IO 2 基板ケーブル組	1
17		401-05114	IO3 PCB CABLE ASSY	IO 3 基板ケーブル組	1
18		401-05090	I/O1 PCB ASSY	I/O 1 基板組	1
19		401-05058	I/O2 PCB ASSY	I/O 2 基板組	1
20		401-05068	I/O3 PCB ASSY	I/O 3 基板組	1
21		401-05030	MAIN PCB ASSY	MAIN 基板組	1
22		401-05133	THD WINDER CABLE 2 ASSY	糸巻電源ケーブル2組	1
23		401-05132	THD WINDER CABLE 1 ASSY	糸巻電源ケーブル1組	1
24		138-70258	BOBBIN THREAD WIDING DEVICE	糸巻装置(結合)	1
25		401-05121	EARTH CABLE ASSY	アースケーブル組	1
26		401-05135	AT SOLENOID CABLE 2 ASSY	AT ソレノイドケーブル2組	1
27		401-05134	AT SOLENOID CABLE 1 ASSY	AT ソレノイドケーブル1組	1
28		400-16908	AT SOLENOID	AT ソレノイド	1
29		401-05168	PAUSE SWITCH CORD ASSY	一時停止スイッチコード組	1
30		400-82736	SDC-MAIN CORD S ASSY	SDC-MAINコードS組	1
31		401-05078	SDC-MAIN CORD P ASSY	SDC-MAINコードP組	1
32	#03	400-90589	REACTOR	リアクター	1
33	#02	400-05393	FLT-SDC CORD P ASSY	FLT-SDCコードP組	1
34		400-05394	FLT-SDC CORD S ASSY	FLT-SDCコードS組	1
35	#03	400-51320	FLT-T PCB B ASSY	FLT-T 基板B組	1
36	#01	400-00046	FLT-S PCB A ASSY	FLT-S 基板A組	1
37	#03	400-86465	POWER CORD 3P ASSY	電装電源コード3P組	1
38	#01	400-86466	POWER CORD JE ASSY	電装電源コードJE組	1
39		HA-0062800-00	SWITCH	スイッチ	1
40		HA-0062800-10	SWITCH	スイッチ	1
41		HA-0062800-20	SWITCH	スイッチ	1
42		HA-0062800-30	SWITCH	スイッチ	1
43		400-91335	OFF SW BOX GND PLATE	非常停止 SW ボックス GND 板	1
44	#03	401-05088	EMERGENCY CABLE 3P ASSY	非常停止電源コード3P組	1
45	#01	401-05089	EMERGENCY CABLE 1P ASSY	非常停止電源コード1P組	1
46		HA-0058200-00	SWITCH	スイッチ	1
47	#03	400-58398	AC POWER CORD C ASM.	AC 電源コードC組	1
48	#01	400-58397	AC POWER CORD B ASM.	AC 電源コードB組	1
49		G6951-172-CA0	HITACHI POWER CORD COMPL.	日立プロア電源コード完成品	1
50		400-31485	FAN POWER CABLE	ファン電源ケーブル	1
51		400-05401	FAN MOTOR ASSY	ファンモータ組	2
52		400-82758	SDC PCB A ASSY	SDC 基板A組	1
53		401-05109	SERVO MOTOR S CORD ASSY	サーボモータ S コード組	1
54		401-05108	SERVO MOTOR P CORD ASSY	サーボモータ P コード組	1
55		400-52937	550W SERVO MOTOR	550W サーボモータ	1
56		HA-0000600-0C	SWITCH	スイッチ	1
57	#01	401-05092	SWITCH BOX CORD ASSY	スイッチボックスコード組	1
		NOTE(注記)	#01....FOR GENERAL EXPORT AND CE(1-PHASE)	一般輸出・CE(单相)用	
			#02....FOR GENERAL EXPORT (1-PHASE)	一般輸出(单相)用	
			#03....FOR GENERAL EXPORT AND USE IN JAPAN (3-PHASE)	一般輸出・日本(3相)用	

33. WIRING DIAGRAM (2)

電装配線図 (2)

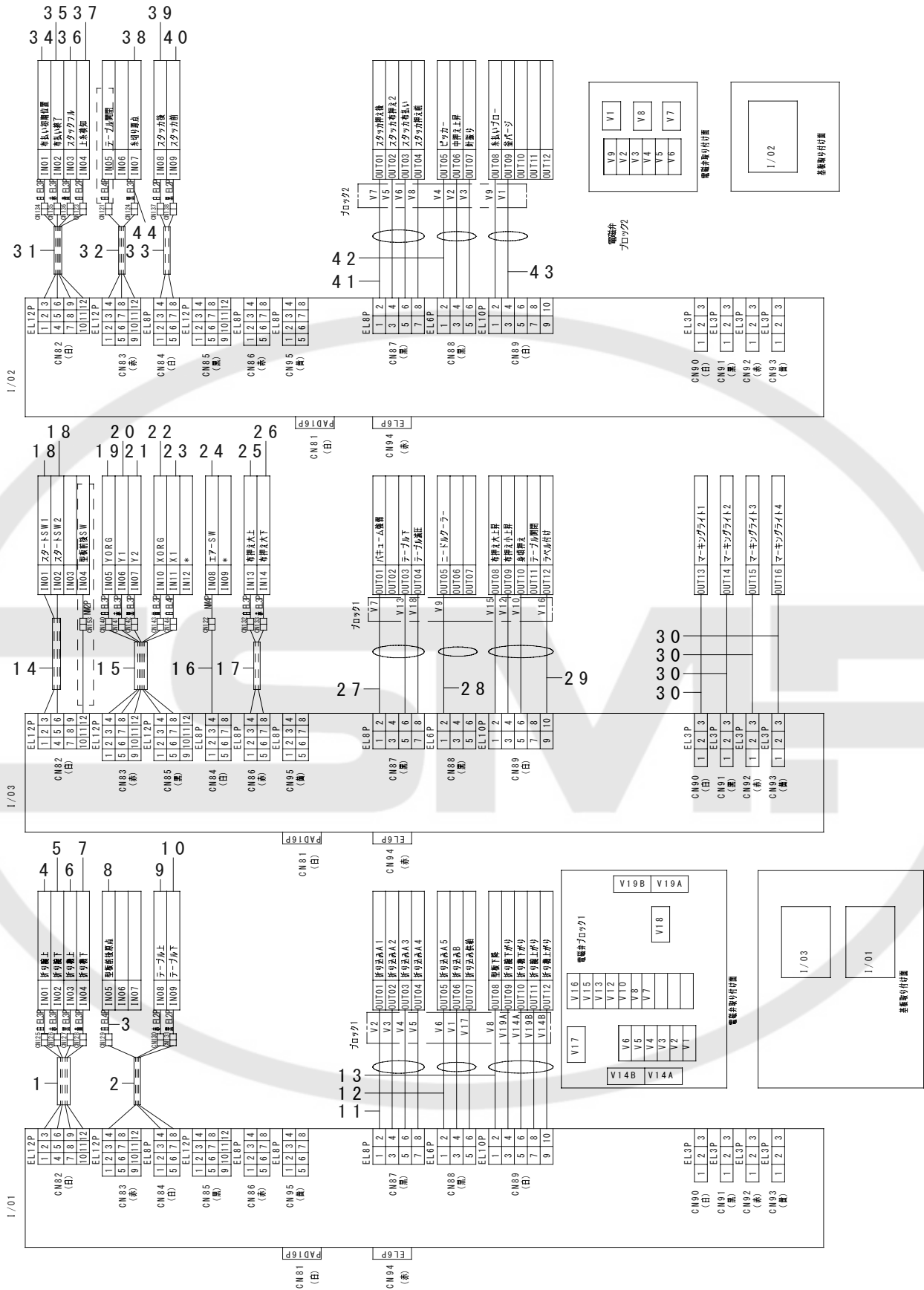

REF.NO	NOTE	PART NO	DESCRIPTION	品名	Qty
1		401-05116	IO1 CN82 CORD ASSY	IO1 CN82コード組	1
2		401-05117	IO1 CN83 CN84 CORD ASSY	IO1 CN83 CN84コード組	1
3		401-05163	K ORG SENSOR ASSY	型板センサコード組	1
4		401-05145	UPPER ORUD SENSOR ASSY	折り腕上センサ組	1
5		401-05146	LOWER ORUD SENSOR ASSY	折り腕下センサ組	1
6		401-05147	UPPER ORKI SENSOR ASSY	折り機上センサ組	1
7		401-05148	LOWER ORKI SENSOR ASSY	折り機下センサ組	1
8		HD-0005700-0A	SENSOR	フォトセンサ	1
9		401-05149	UPPER TABLE SENSOR ASSY	テーブル上センサ組	1
10		401-05150	LOWER TABLE SENSOR ASSY	テーブル下センサ組	1
11		401-05136	IO1 CN87 CORD ASSY	IO1 CN87コード組	1
12		401-05137	IO1 CN88 CORD ASSY	IO1 CN88コード組	1
13		401-05138	IO1 CN89 CORD ASSY	IO1 CN89コード組	1
14		401-05118	IO3 CN82 CORD ASSY	IO3 CN82コード組	1
15		401-05127	X-Y SENSOR CORD ASSY	X-Yセンサコード組	1
16		401-05130	AIR SWITCH CORD ASSY	エアースイッチコード組	1
17		401-05119	IO3 CN86 CORD ASSY	IO3 CN86コード組	1
18		HA-0042900-00	SWITCH	スイッチ(緑)	2
19		401-05151	Y ORG SENSOR ASSY	Y原点センサ組	1
20		401-05152	Y1 SENSOR ASSY	Y1センサ組	1
21		401-05153	Y2 SENSOR ASSY	Y2センサ組	1
22		401-05154	X ORG SENSOR ASSY	X原点センサ組	1
23		401-05155	X1 SENSOR ASSY	X1センサ組	1
24		400-88208	FILTER REGULATOR ASSY	フィルターレギュレータ組	1
25		401-05161	UPPER BIG CLAMP SENSOR ASSY	布押え大上センサ組	1
26		401-05162	LOWER BIG CLAMP SENSOR ASSY	布押え大下センサ組	1
27		401-05139	IO3 CN87 CORD ASSY	IO3 CN87コード組	1
28		401-05144	IO3 CN88 CORD ASSY	IO3 CN88コード組	1
29		401-05140	IO3 CN89 CORD ASSY	IO3 CN89コード組	1
30	#01	401-05166	LED MARKING ASSY	LEDマーキング組	4
31		401-05123	IO2 CN82 CORD ASSY	IO2 CN82コード組	1
32		401-05129	IO2 CN83 CORD ASSY	IO2 CN83コード組	1
33		401-05120	IO2 CN84 CORD ASSY	IO2 CN84コード組	1
34		401-05156	DRIVE AWAY ORG SENSOR ASSY	布払い初期位置センサ組	1
35		401-05157	DRIVE AWAY END SENSOR ASSY	布払い終了センサ組	1
36		401-05158	STACKER FULL SENSOR ASSY	スタッカフルセンサ組	1
37		401-05165	THB SENSOR ASSY	糸切れ検知組	1
38		HD-0005700-0A	SENSOR	フォトセンサ	1
39		401-05159	STACKER BEHIND SENSOR ASSY	スタッカ後センサ組	1
40		401-05160	STACKER FRONT SENSOR ASSY	スタッカ前センサ組	1
41		401-05141	IO2 CN87 CORD ASSY	IO2 CN87コード組	1
42		401-05142	IO2 CN88 CORD ASSY	IO2 CN88コード組	1
43		401-05143	IO2 CN89 CORD ASSY	IO2 CN89コード組	1
44		401-05164	TRM ORG SENSOR ASSY	糸切り原点センサコード組	1
		NOTE(注記)	#01....OPTIONAL PARTS	オプション部品	

34. THREAD STAND COMPONENTS

糸立装置関係

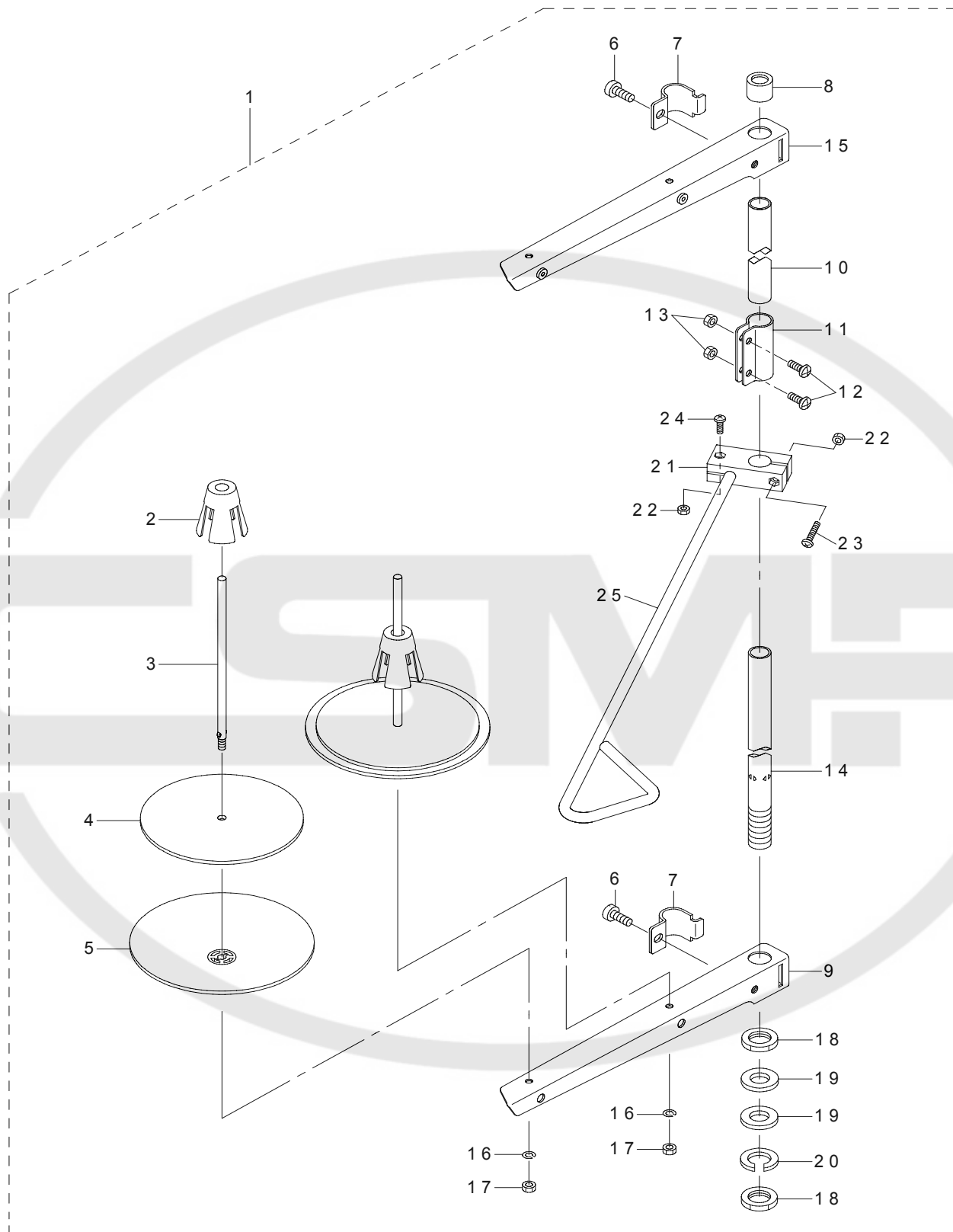

REF.NO	NOTE	PART NO	DESCRIPTION	品名	Qty
1		269-10653	THREAD STAND ASM.	糸立装置 (組)	1
2		229-31109	SPOOL RETAINER	糸巻振れ止め	(2)
3		229-31000	SPOOL PIN	糸巻受棒	(2)
4		229-30903	SPOOL REST CUSHION	糸巻受皿クッション	(2)
5		229-30804	SPOOL REST	糸巻受皿	(2)
6		SM-6061610-SC	SCREW M6 L=16	平小ねじ M 6 L = 1 5	(2)
7		229-30705	THREAD GUIDE ARM JOINT	糸立棒締金具	(2)
8		229-31406	SPOOL REST ROD RUBBER CAP	糸立棒保護ゴム	(1)
9		229-30507	SPOOL REST ARM	糸立腕	(1)
10		229-30408	SPOOL REST ROD, UPPER	糸立棒 (上)	(1)
11		229-31307	SPOOL REST ROD JOINT	糸立棒継手	(1)
12		SM-4051405-SE	SCREW M5 L=14	なべ小ねじ M 5 L = 1 4	(2)
13		NM-6050001-SE	NUT M5	六角ナット M 5	(2)
14		229-30309	SPOOL REST ROD, LOWER	糸立棒 (下)	(1)
15		229-30556	THREAD STANDING ARM ASM.	糸立腕 (組)	(1)
16		WS-0510002-KN	SPRING WASHER	ばね座金 5. 1 X 9. 2 X 1. 3	(2)
17		NM-6050001-SE	NUT M5	六角ナット M 5	(2)
18		NM-6160511-SE	NUT M16X1.5	六角ナット M 1 6 X 1. 5 1種	(2)
19		WP-1612616-SE	WASHER 16X30X2.6	平座金	(2)
20		WS-1643202-KR	SPRING WASHER	ばね座金 1 6. 4 X 2 6. 6 X 3. 2	(1)
21		131-68208	THREAD GUIDE ARM BASE	糸立糸案内腕台	(1)
22		NM-6040002-SE	NUT M4X0.7	六角ナット M 4 X 0. 7 2種	(2)
23		SM-4042001-SC	SCREW M4 X 20	なべ小ねじ M 4 X 0. 7 L = 2 0	(1)
24		SM-4041201-SC	SCREW M4 L=12	なべ小ねじ M 4 L = 1 2	(1)
25		269-10604	THREAD GUIDE B	糸立糸案内 (B)	(1)



35. ACCESSORIES COMPONENTS

付属品関係

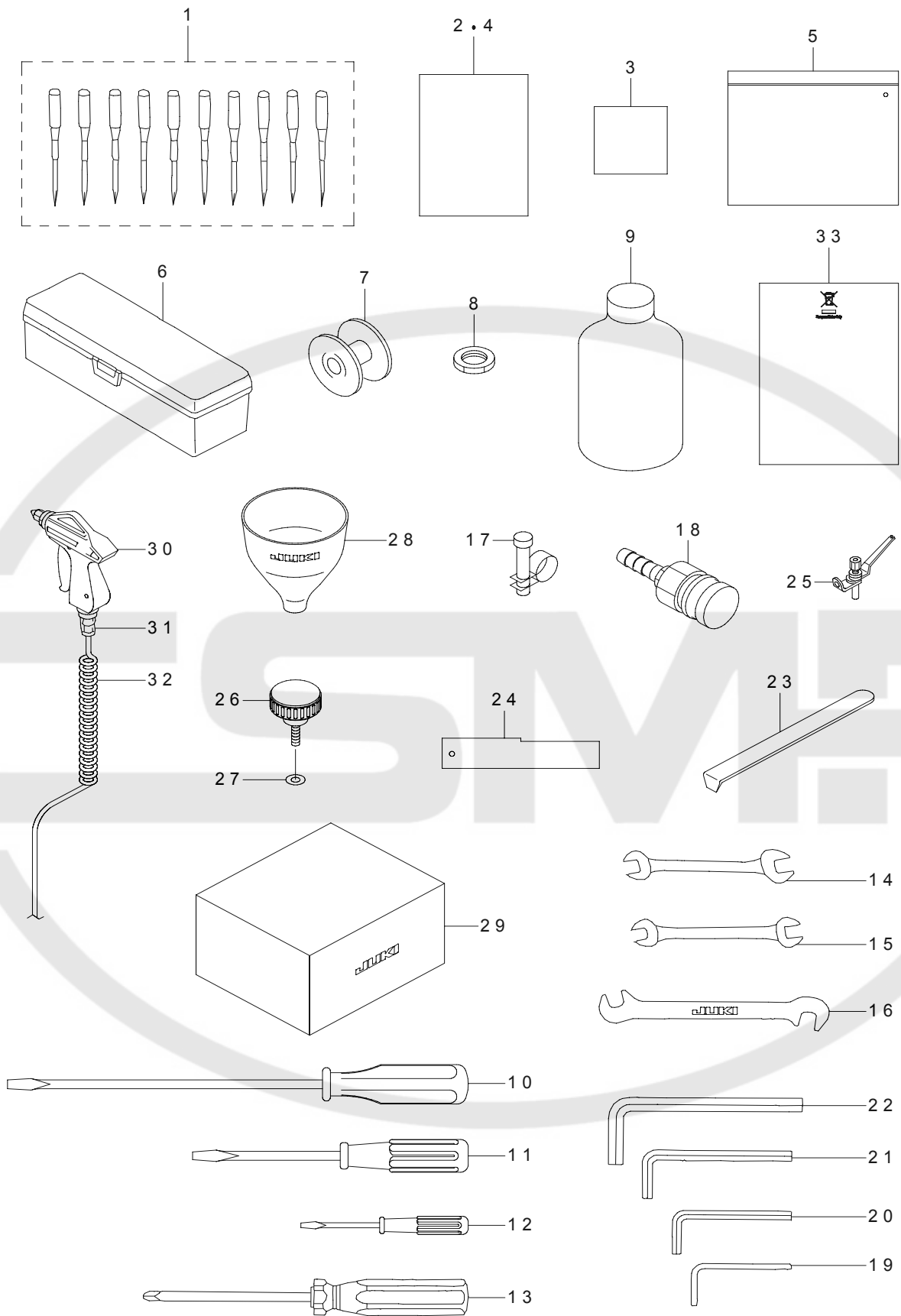

REF.NO	NOTE	PART NO	DESCRIPTION	品名	Qty
1		MC-2005313-0T	NEEDLE (SCHMETZ 134 SERV 7) #130-10	針 (シュメツ 134 SERV 7) NM130-10	1
2		401-16683	AP-876 PARTS LIST	AP-876 パーツリスト	1
3		401-16684	AP-876 INSTRUCTION CD	AP-876 取扱説明書 CD	1
4		401-16685	AP-876 SAFETY INSTRUCTION	AP-876 安全注意書	1
5		229-32800	ACCESSORIE BAG	付属品/バッグ	1
6		B8601-WP1-0A0	TOOL BOX ASM.	工具箱組	1
7		G1817-875-000	BOBBIN	ボビン	3
8		NM-6160511-SE	NUT M16X1.5 TYPE1	六角ナット M16 X 1.5 1種	1
9		MDF-RX1600C0	DEFRIX OIL NO.1 (600CC)	デフレックスオイル NO.1 (600 CC)	2
10		229-33006	SCREW DRIVER	ドライバー (大)	1
11		229-33105	SCREW DRIVER	ドライバー (中)	1
12		229-33204	SCREW DRIVER	ドライバー (小)	1
13		J1071-000-000	CROSS SCREW DRIVER 2	十字ねじ回し (2番)	1
14		D9103-555-D00	WRENCH 6X7	両口スパナ 6 X 7	2
15		B9110-804-000	WRENCH (8X9)	スパナ 8 X 9	1
16		B9109-804-000	WRENCH (6X6)	主送り腕ピンスパナ	1
17		PB-0000100-00	HOSE BAND	ホースバンド	1
18		PJ-3095200-01	HIGH COUPLER SOCKET	ハイカプラソケット	1
19		B9141-372-000	HEXAGONAL WRENCH	六角棒スパナ (大)	1
20		B9140-372-000	HEXAGONAL WRENCH	六角棒スパナ (小)	1
21		GCT-02906000	HEXAGONAL SPANNER	六角棒スパナ	1
22		B9142-372-000	HEXAGONAL WRENCH (7.1X8.1)	六角棒スパナ (7.1 X 8.1)	1
23		B9101-490-000	DRIVER	ドライバー	1
24		G9101-875-000	HOOK TIMING GAUGE	釜タイミングゲージ	1
25		D1113-126-WA0	NEEDLE THREAD GUIDE PIN ASM.	糸案内棒組	1
26		G6007-875-000	FOLDING UNIT INSTALLING KNOB	折り機取り付けフ	2
27		WP-0550836-SC	WASHER 5.5X12X0.8	平座金 5.5 X 12 X 0.8	2
28		131-60601	FUNNEL	ジョーゴ	1
29		400-55297	HEAD COVER	頭部カバー	1
30		400-44823	AIR GUN	エアガン	1
31		PJ-3010652-01	HALF UNION 6XPT1/4	ハーフユニオン 6 X P T 1 / 4	1
32		GSS-36020000	COIL TUBE	コイルチューブ	1
33	#01	CM-6001002-01	WEEE INFORMATION SHEET	WEEE インフォメーション シート	1
		NOTE(注記)	#01....FOR CE	CE 用	

36. MARKING LIGHT COMPONENTS (OPTION)

マーキングライト関係 (オプション)

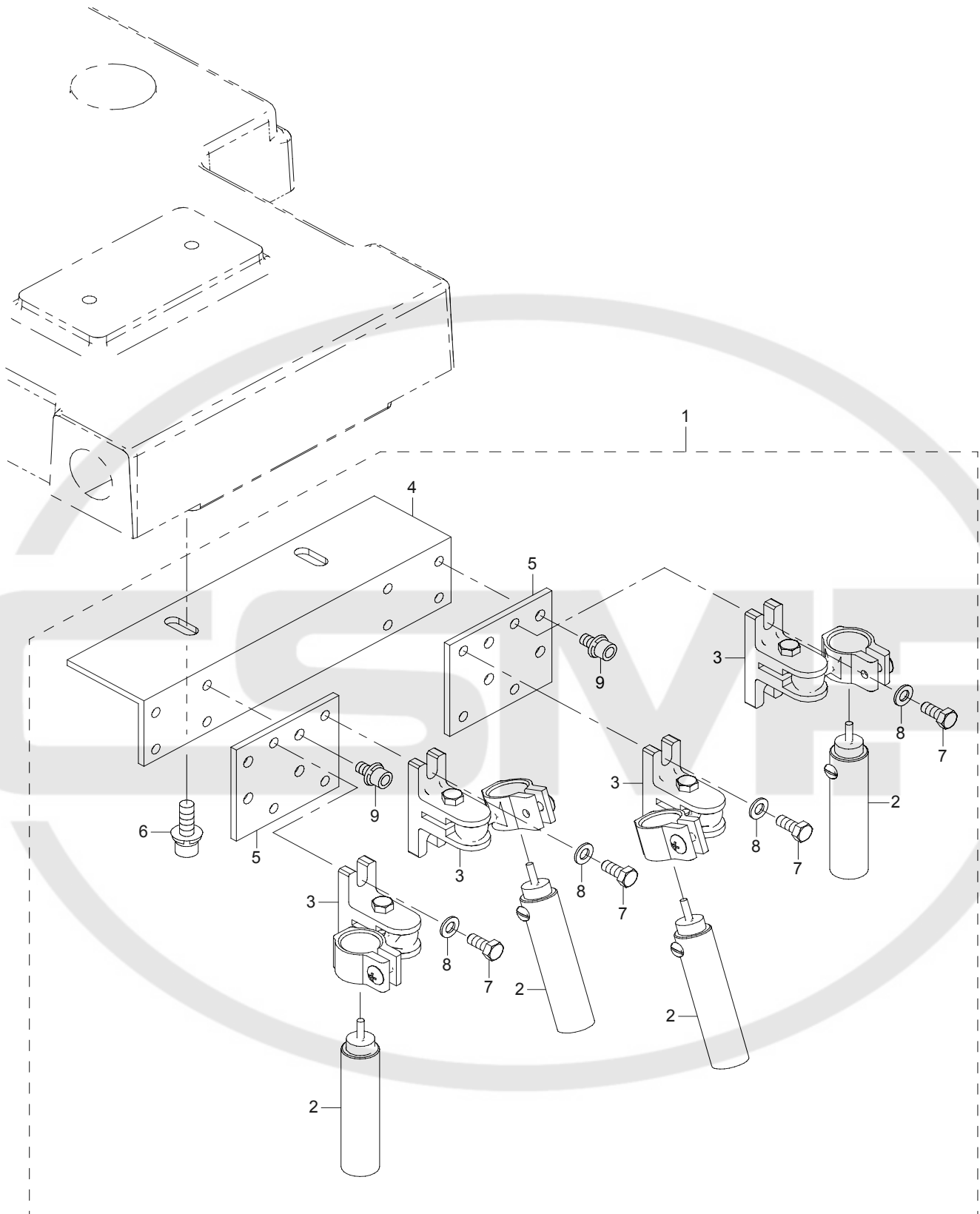

REF.NO	NOTE	PART NO	DESCRIPTION	品 名	Qty
1		401-16756	PH=MARKER	マーキングライト組	1
2		401-05166	LED MARKING ASSY	LED マーキング組	(4)
3		HE-0005500-10	LAMP	マーキングライト取付け台	(4)
4		401-19303	MARKING LIGHT SUPPORT PLATE	マーキングライト取付け板	(1)
5		401-19293	MARKING LIGHT PLATE	マーキングライト板	(2)
6		SL-6062092-TN	SCREW M6 L=20	座金付き六角穴ボルト M 6 L = 20	(2)
7		SM-9051203-SE	SCREW M5X0.8 L=12	六角ボルト M 5 X 0. 8 L = 1 2	(8)
8		WP-0531000-SE	WASHER	平座金	(8)
9		SL-6051092-TN	SCREW M5 L=10	座金付き六角穴ボルト M 5 L = 1 0	(8)



37. GARMENT PUT BASE COMPONENTS (OPTION)

身頃置き台関係 (オプション)

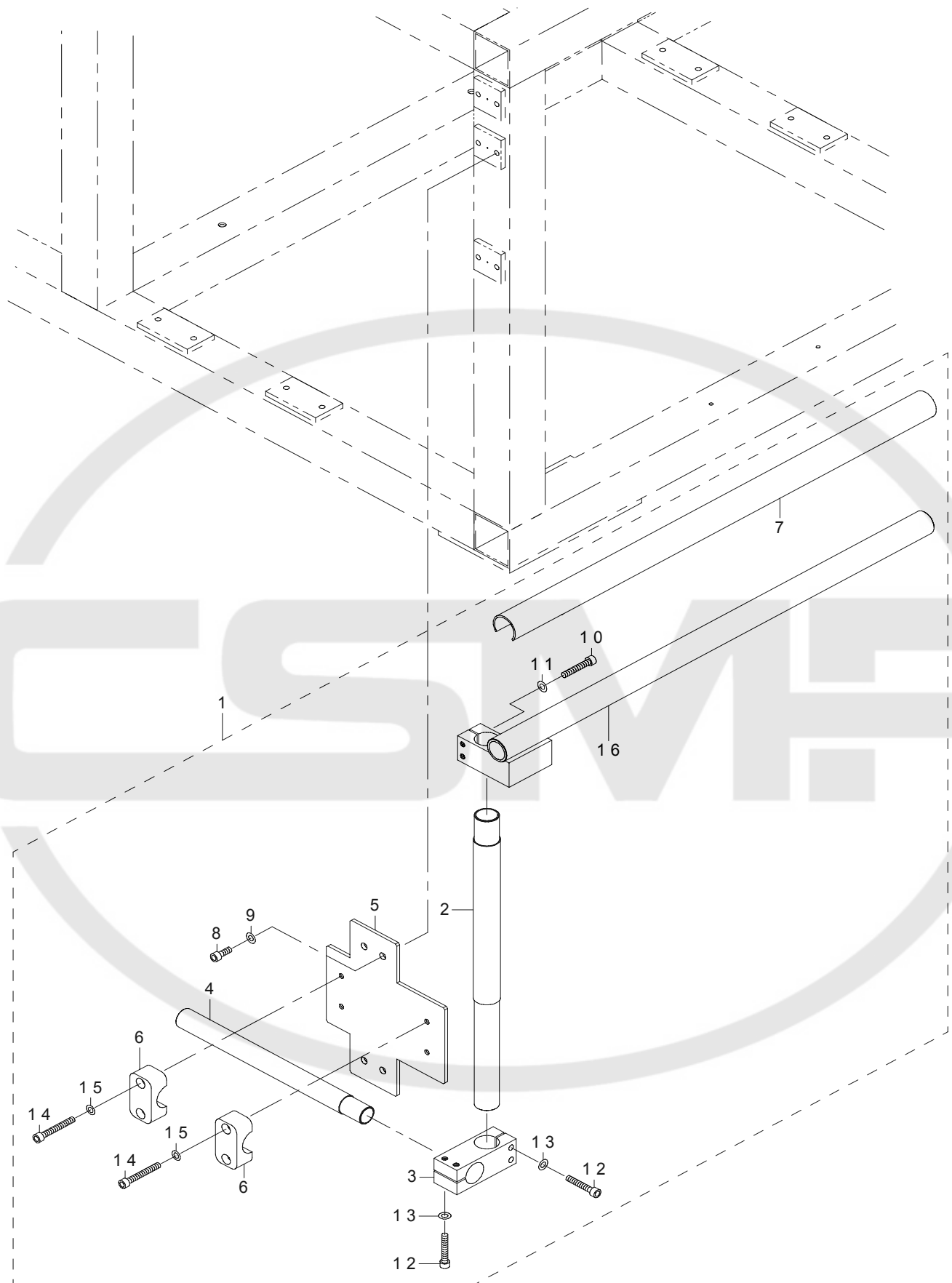

REF.NO	NOTE	PART NO	DESCRIPTION	品名	Qty
1		G9011-875-0B0	GARMENT PUT BASE ASM.	身頃置き台組	1
2		G9013-875-000	GARMENT PUT BASE STRUT A	身頃置き台支柱 A	(1)
3		G9014-875-000	GARMENT PUT BASE COUPLING	身頃置き台継手	(1)
4		G9015-875-000	GARMENT PUT BASE STRUT B	身頃置き台支柱 B	(1)
5		G9016-875-000	GARMENT PUT BASE FITTING BASE	身頃置き台取付土台	(1)
6		G9017-875-000	PIPE CLAMP	パイプクランプ	(4)
7		G9018-875-000	GARMENT PUT BASE RUBBER	身頃置き台ラバー	(1)
8		SM-6061602-TN	SCREW M6 L=16	六角穴ボルト M 6 L = 1 6	(4)
9		WP-0641601-SC	WASHER	平座金みがき丸 M 6	(4)
10		SM-6063502-TN	HEXAGONAL-HOLE BOLT M6 L=35	六角穴ボルト M 6 L = 3 5	(2)
11		WP-0641601-SC	WASHER	平座金みがき丸 M 6	(2)
12		SM-6063502-TN	HEXAGONAL-HOLE BOLT M6 L=35	六角穴ボルト M 6 L = 3 5	(4)
13		WP-0641601-SC	WASHER	平座金みがき丸 M 6	(4)
14		SM-6064502-TP	SCREW M6 L=45	六角穴ボルト	(4)
15		WP-0641600-SC	WASHEW 6.4X12.5X1.6	平座金	(4)
16		G9011-875-0A0	GARMENT PUT BASE PIPE COMPL.	身頃置き台パイプ結合	(1)



38. BAR CODE READER (OPTION)
 バーコードリーダー (オプション)

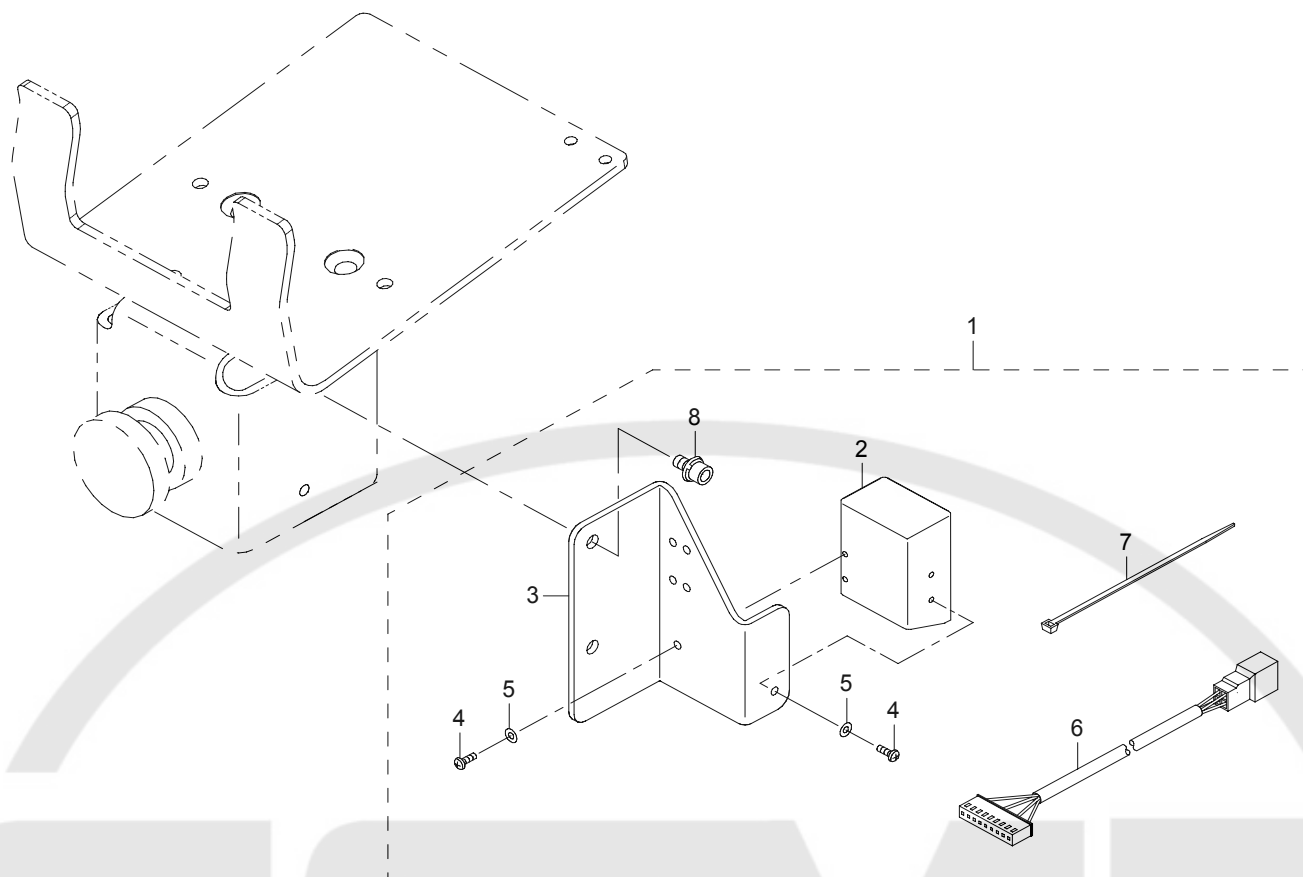

REF.NO	NOTE	PART NO	DESCRIPTION	品名	Qty
1		401-19168	PH=BARCODE READER	バーコードリーダー組	1
2		400-89237	BAR CODE READER ASSY	バーコードリーダー組	(1)
3		400-89027	BAR CODE READER BRACKET	バーコードリーダーブラケット	(1)
4		SM-4020601-SC	SCREW M2 L=6	なべ小ねじ M2 L=6	(2)
5		WP-0220301-SC	WASHER M2	平座金みがき丸 M2	(2)
6		401-05095	BAR CODE READER CABLE B ASSY	バーコードリーダーケーブル B 組	(1)
7		EA-9500B01-00	CABLE BAND	束線バンド	(2)
8		SL-6040892-TN	SCREW M4 L=8	座金付き六角穴ボルト M4 L=8	(2)

NUMERICAL INDEX OF PARTS

索引

PART NO 品番	PAGE 頁	REF NO	PART NO 品番	PAGE 頁	REF NO	PART NO 品番	PAGE 頁	REF NO	PART NO 品番	PAGE 頁	REF NO
A1230-500-000-A	4	33	CM-3001000-04	62	47	G1405-875-0A0	8	11	G5344-172-000	46	10
BT-0400251-EB	12	6	CM-3001004-01	62	49	G1415-875-0A0	8	25	G5345-172-000	46	9
BT-0400251-EB	12	7	CM-3002000-01	2	23	G1415-875-000	8	26	G5453-161-000	36	18
BT-0400251-EB	16	29	CM-3002000-01	12	31	G1416-875-000	8	28	G5454-161-000	28	46
BT-0400251-EB	16	30	CM-3002000-03	38	62	G1421-875-000	10	1	G5501-875-000	38	39
BT-0400251-EB	16	30	CM-3004006-01	62	48	G1422-875-000	10	20	G5502-875-000	38	40
BT-0400251-EB	48	61	CM-6001001-01	60	14	G1423-875-000	10	21	G5503-875-000	38	41
BT-0400251-EB	52	68	CM-6001001-01	62	43	G1424-875-000	10	7	G5504-875-000	38	42
BT-0400251-EB	54	58	CM-6001002-01	70	33	G1426-875-000	10	17	G5511-875-000	38	54
BT-0500300-EA	22	37	CQ-2020000-00	22	34	G1427-875-000	10	27	G5523-880-000	42	54
BT-0500300-EA	22	38	CQ-2520000-00	2	44	G1428-875-000	10	29	G5611-341-000	52	67
BT-0500300-EA	22	39	CQ-3000000-F0	8	44	G1429-875-000	10	41	G6007-875-000	70	26
BT-0500300-EA	22	40	CQ-3000000-F0	22	35	G1430-875-000	10	42	G6008-875-000	40	41
BT-0500300-EA	22	41	CQ-3030000-00	22	33	G1431-875-000	10	13	G6010-870-000	40	36
BT-0500300-EA	22	55	CS-0640611-SP	50	5	G1601-875-0A0	12	1	G6012-870-000	42	64
BT-0500300-EG	22	29	CS-079073A-SH	16	21	G1601-875-000	12	2	G6014-870-000	42	65
BT-0500300-EG	22	36	CS-0800971-TP	42	9	G1603-875-000	12	18	G6014-880-000	54	50
BT-0500300-EG	24	1	CS-1000881-TP	42	8	G1604-875-000	12	21	G6015-875-000	54	51
BT-0600401-EB	48	60	CS-140101A-SP	8	22	G1605-870-000	12	24	G6016-870-0A0	42	66
BT-0600401-EB	52	69	CS-140101A-SP	10	38	G1606-875-000	12	22	G6016-875-000	54	52
BT-0800501-EB	48	59	CS-1401014-SP	8	24	G1610-870-000	12	26	G6017-875-000	54	5
B1123-205-000	46	5	CS-1401014-SP	10	39	G1611-870-000	12	23	G6019-870-000	56	5
B1144-210-000	4	37	CS-150101A-TH	4	17	G1801-875-000	16	1	G6023-870-000	40	15
B1172-581-000-A	26	7	CS-1501171-TP	34	43	G1802-875-0A0	16	2	G6028-870-000	40	16
B1211-980-000	4	16	CS-1501171-TP	52	39	G1802-875-000	16	3	G6028-875-000	40	33
B1212-210-D00	4	32	CS-1601211-TH	42	50	G1803-875-000	16	4	G6029-875-000	40	34
B1213-552-000-A	4	2	CS-1801211-SH	40	24	G1804-870-000	16	31	G6031-870-000	54	48
B1214-038-000	22	24				G1805-870-000	16	32	G6040-870-000	40	17
B1215-552-000	4	4	D1113-126-WA0	70	25	G1806-870-0B0	16	33	G6108-870-000	42	63
B1220-771-000	4	15	D2419-530-D00	38	46	G1808-870-000	16	6	G6110-875-000	56	2
B1226-552-000	4	3	D3902-481-C00-A	4	34	G1810-870-000	16	8	G6111-870-000	56	7
B1306-155-0A0	6	1	D9103-555-D00	70	14	G1811-870-0A0	16	9	G6112-875-000	58	3
B1307-155-0A0	6	2				G1813-870-0A0	16	10	G6113-875-00A	58	16
B1308-155-0A0	16	20	EA-9500B01-00	22	54	G1813-870-000	16	11	G6113-875-000	58	4
B1410-771-000	8	5	EA-9500B01-00	36	16	G1816-875-0A0	16	7	G6114-875-000	56	6
B1414-232-000	8	7	EA-9500B01-00	38	69	G1817-875-000	16	26	G6115-875-000	56	3
B1432-761-000	10	52	EA-9500B01-00	52	73	G1817-875-000	70	7	G6116-875-000	56	4
B1432-761-000	38	27	EA-9500B01-00	75	7	G1902-875-0A0	8	46	G6118-870-000	52	46
B1504-051-000	12	16	EA-9500B02-00	36	17	G2313-870-000	14	16	G6119-875-0A0	58	10
B1504-210-000	38	6	E2314-715-000	34	53	G2406-870-000	18	25	G6119-875-000-A	58	11
B1611-220-000	12	14	E9567-319-000	62	12	G2408-870-000	18	27	G6120-875-0A0	58	13
B1618-804-000	18	31				G2409-875-0A0	18	3	G6120-875-000-A	58	14
B1632-180-000	54	44	GAC-01002A00	34	8	G2409-875-000	18	4	G6122-875-000	58	12
B1802-180-000	34	26	GAC-01002A00	42	27	G2410-870-000	18	5	G6202-875-000	44	3
B1802-180-000	34	31	GAK-01003B00	38	55	G2415-875-000	18	44	G6203-875-000	44	7
B1802-180-000	34	40	GAK-33032000	52	81	G2416-875-000	18	45	G6204-875-000	44	11
B1850-512-000	22	48	GCT-02906000	70	21	G2417-875-000	18	46	G6205-875-000	44	14
B1903-552-000	8	54	GLA-02302000	38	58	G2418-875-000	18	12	G6206-875-000	34	88
B1905-541-A00	8	48	GMC-10004000	46	12	G2419-875-000	18	13	G6206-875-000	36	1
B1905-541-B00	8	49	GMC-100050A0	46	11	G2420-875-000	18	14	G6206-875-000	44	16
B1905-541-C00	8	50	GMC-10007000	46	13	G2421-875-000	18	38	G6207-875-000-A	44	17
B1905-541-D00	8	51	GMC-16005000	46	33	G2422-875-000	18	15	G6208-875-000-A	44	19
B2006-372-000	10	37	GSS-36020000	70	32	G3216-270-000	50	10	G6210-875-000	44	31
B2504-221-D00	34	68	G1015-192-000	28	33	G3513-870-000	24	6	G6211-875-000	44	20
B2505-221-D00	34	77	G1015-192-000	28	39	G3514-870-000	24	5	G6213-875-000	44	36
B2557-280-00A	18	17	G1016-192-000	28	32	G3515-870-000	24	2	G6214-875-000	44	39
B2703-210-000	14	17	G1016-192-000	28	38	G3516-875-000	22	52	G6215-875-0A0	44	41
B3118-352-000	22	46	G1111-875-000	2	4	G3517-875-0A0	22	25	G6252-875-0A0	46	17
B3212-761-000	50	7	G1112-875-000	2	7	G3517-875-000	22	26	G6253-875-000	46	28
B3502-210-000	2	42	G1113-875-000	2	1	G3519-870-000	24	20	G6505-880-000	10	6
B3508-220-000	22	64	G1116-875-000	2	10	G3520-870-000	24	16	G6951-172-CA0	46	3
B3509-220-000	2	43	G1117-875-000	2	5	G3522-870-000	22	12	G6951-172-CA0	64	49
B3534-155-000	22	23	G1118-875-000	2	8	G3526-870-000	24	12	G7515-870-000	26	29
B3541-012-000	22	32	G1119-875-000	2	2	G3527-870-000	24	13	G7521-870-000	26	34
B3570-771-000	22	44	G1135-870-000	2	38	G3528-870-000	24	14	G7524-870-000	26	26
B4004-210-D00	42	61	G1206-875-000	4	11	G3528-875-000	24	7	G7524-870-000	52	54
B4420-373-000	46	4	G1211-870-000	16	16	G3529-870-000	24	15	G7525-870-000	26	25
B8601-WP1-0A0	70	6	G1212-870-0A0	4	13	G3529-875-000	24	8	G8010-875-000	28	26
B9101-490-000	70	23	G1216-870-000	4	22	G3531-875-000	22	8	G8011-870-000	26	10
B9109-804-000	70	16	G1216-870-000	34	41	G3532-875-0A0	2	41	G8012-870-000	26	11
B9110-804-000	70	15	G1220-870-000-A	4	21	G5006-870-000	32	17	G8013-875-000	28	1
B9140-372-000	70	20	G1301-875-000	6	5	G5026-162-000	26	22	G8014-875-000	28	3
B9141-372-000	70	19	G1302-875-000	6	3	G5030-171-000	32	16	G8018-875-000	26	30
B9142-372-000	70	22	G1303-870-000	16	15	G5171-136-000	46	32	G8031-875-0A0	50	1
			G1401-875-000	8	40	G5176-136-000	46	34	G8031-875-000	50	2

NUMERICAL INDEX OF PARTS

索引

PART NO 品番	PAGE 頁	REF NO	PART NO 品番	PAGE 頁	REF NO	PART NO 品番	PAGE 頁	REF NO	PART NO 品番	PAGE 頁	REF NO
G8032-875-0A0	50	16	NM-3040520-SC	62	22	PJ-0460525-03	54	43	SB-1300002-00	34	72
G8033-875-000	50	9	NM-3040520-SC	62	26	PJ-2300043-00	42	40	SB-1300003-00	34	73
G8113-875-000	26	16	NM-6020001-SC	14	33	PJ-3010405-02	44	48	SB-6160001-00	42	55
G9011-875-0A0	74	16	NM-6030001-SC	14	37	PJ-3010605-03	48	39	SD-0500166-TP	54	36
G9011-875-0B0	74	1	NM-6030001-SC	46	16	PJ-3010651-03	48	19	SD-0500204-TP	18	1
G9013-875-000	74	2	NM-6040001-SC	44	6	PJ-3010652-01	48	26	SD-0500231-TP	18	9
G9014-875-000	74	3	NM-6040001-SC	44	10	PJ-3010652-01	48	31	SD-0600181-TP	18	18
G9015-875-000	74	4	NM-6040001-SC	46	22	PJ-3010652-01	70	31	SD-0600403-TP	18	32
G9016-875-000	74	5	NM-6040001-SC	58	7	PJ-3030400-02	38	65	SD-0640391-TP	18	19
G9017-875-000	74	6	NM-6040001-SP	20	23	PJ-3030400-02	52	66	SD-0640752-TP	18	24
G9018-875-000	74	7	NM-6040002-SE	68	22	PJ-3030600-01	48	58	SD-0800327-TP	20	24
G9101-875-000	70	24	NM-6050001-SC	28	7	PJ-3040405-04	10	3	SD-0800402-TP	10	33
HA-0000600-0C	28	10	NM-6050001-SC	28	29	PJ-3040405-04	12	33	SL-4020591-SC	20	10
HA-0000600-0C	64	56	NM-6050001-SC	44	45	PJ-3040405-04	18	35	SL-4020591-SC	42	12
HA-0042900-00	28	2	NM-6050001-SE	46	26	PJ-3040405-04	24	10	SL-4030681-SC	60	8
HA-0042900-00	66	18	NM-6050001-SE	52	61	PJ-3040405-04	38	11	SL-4030681-SC	60	11
HA-0042900-10	28	11	NM-6050001-SE	68	13	PJ-3040405-04	46	27	SL-4030881-SC	60	13
HA-0058200-00	26	45	NM-6050001-SE	68	17	PJ-3040405-04	48	22	SL-4030891-SC	34	19
HA-0058200-00	64	46	NM-6050003-SC	22	62	PJ-3040405-05	48	40	SL-4030891-SC	48	38
HA-0058200-00	64	46	NM-6060001-SC	2	28	PJ-3040605-02	48	23	SL-4031091-SC	48	34
HA-0062800-00	28	12	NM-6060001-SC	26	33	PJ-3040605-02	48	35	SL-4031091-SC	48	67
HA-0062800-00	64	39	NM-6060001-SC	28	43	PJ-3040651-01	44	26	SL-4031291-SC	20	32
HA-0062800-10	28	13	NM-6060001-SC	28	33	PJ-3040651-01	48	12	SL-4033091-SC	62	46
HA-0062800-10	64	40	NM-6060001-SC	34	14	PJ-3040651-01	48	12	SL-4040881-SC	48	11
HA-0062800-20	28	14	NM-6060001-SC	34	37	PJ-3040651-01	48	46	SL-4040881-SC	48	11
HA-0062800-20	64	41	NM-6060001-SC	38	57	PJ-3040652-01	48	30	SL-4040881-SC	62	18
HA-0062800-30	64	41	NM-6060001-SC	46	8	PJ-3050400-01	38	13	SL-4040881-SC	62	20
HA-0062800-30	28	15	NM-6080001-SC	46	8	PJ-3050400-01	38	63	SL-4040881-SC	62	28
HA-0062800-30	64	42	NM-6080001-SC	26	42	PJ-3050600-04	48	14	SL-4040881-SC	62	54
HD-0005700-0A	20	31	NM-6080001-SC	44	32	PJ-3080400-02	16	34	SL-4040891-SC	46	18
HD-0005700-0A	42	60	NM-6100001-SC	62	13	PJ-3080400-02	54	59	SL-4040891-SC	62	7
HD-0005700-0A	66	8	NM-6160511-SE	52	75	PJ-3080600-03	44	28	SL-4040891-SC	62	8
HD-0005700-0A	66	38	NM-6160511-SE	68	18	PJ-3080600-03	48	13	SL-4040891-SC	62	16
HD-0027800-00	20	9	NM-6260810-SC	70	8	PJ-3080600-04	48	16	SL-4040891-SC	62	45
HD-0027800-00	42	2	NS-6090310-SP	52	20	PJ-3080600-04	48	50	SL-4040891-SC	62	51
HD-0027800-00	64	3	NS-6090310-SP	2	37	PJ-3080800-03	48	51	SL-4041081-SC	26	23
HE-0005500-10	72	3	NS-6110350-SP	22	50	PJ-3080800-04	48	57	SL-4041081-SC	28	45
HM-0005500-10	46	19	NS-6110360-SP	2	39	PJ-3080852-02	48	56	SL-4041091-SC	28	18
HW-0021802-00	60	15	NS-6110420-SP	56	18	PJ-3095200-01	70	18	SL-4041091-SC	38	68
HX-0001300-0C	26	43	NS-6110420-SP	10	54	PJ-4010003-00	40	39	SL-4041091-SC	40	49
HX-0005500-00	46	31	NS-6110420-SP	22	6	PJ-4010004-00	54	57	SL-4041091-SC	48	5
HX-0015000-0C	36	14	NS-6150310-SP	50	4	PS-0200052-KH	58	15	SL-4041091-SC	48	25
HX-0015000-0C	38	66	NS-6150310-SP	8	6	PS-0400142-KH	4	31	SL-4041091-SC	48	29
HX-0015000-0C	50	15	NS-6150310-SP	10	24	PV-1306001-00	48	37	SL-4041091-SC	48	63
HX-0015000-0C	54	61	NS-6150310-SP	10	45	PV-1502130-00	48	24	SL-4041091-SC	48	65
HX-0015000-0D	52	71	NS-6150310-SP	10	46	PV-1502140-00	48	28	SL-4041091-SC	52	72
HX-0015000-0E	40	48	NS-6150430-SP	10	48	PV-1502150-00	48	33	SL-4041091-SC	54	64
HX-0015000-0E	52	70	NS-6150430-SP	18	30	PV-2051010-00	48	17	SL-4041091-SC	62	31
HX-0015000-0E	54	62	PA-1001013-A0	38	28	PX-0505010-00	48	36	SL-4041091-SC	62	42
HX-0015000-0G	38	67	PA-1501010-A0	18	34	PX-0505010-00	48	41	SL-4042091-SC	38	64
HX-0015000-0H	54	63	PA-1502008-A0	10	2	PX-0551040-00	48	27	SL-4042091-SC	48	15
HX-0015000-0M	40	47	PA-1601515-A0	54	31	RC-3781518-KP	48	32	SL-4043091-SC	38	14
HX-0023300-00	54	60	PA-1602014-A0	44	46	RE-0300000-K0	52	12	SL-4043091-SC	48	7
HX-0031400-0A	48	48	PA-2000511-00	54	41	RE-0320000-K0	38	17	SL-4043091-SC	48	9
HX-0031400-0B	48	49	PA-2001004-A0	42	32	RE-0600000-K0	38	8	SL-4043591-SC	48	45
HX-0031400-00	48	47	PA-2002010-00	38	50	RE-0700000-K0	10	35	SL-4051091-SC	62	25
HX-0032600-0K	62	11	PA-2505003-00	12	3	RO-0291801-00	42	36	SL-4051091-SC	2	19
HX-0033900-00	48	10	PA-9000600-00	46	23	RO-0360802-00	4	27	SL-4051091-SC	48	21
HX-0033900-00	62	21	PB-0000100-00	25	45	RO-0442401-00	14	39	SL-4051091-SC	50	12
HX-0035400-0B	60	12	PC-0124010-00	44	25	RO-0552001-00	4	5	SL-4051091-SC	50	13
HX-0040700-00	62	29	PC-0126010-00	70	17	RO-0981901-00	22	2	SL-4052591-SC	50	14
HX-0041200-00	26	44	PC-0151060-00	38	12	RO-0982401-00	4	10	SL-6030692-TN	48	18
HX-0051100-00	62	38	PC-0151080-00	44	27	RO-1331701-00	20	38	SL-6030692-TN	54	14
J1071-000-000	70	13	PC-0152030-00	40	30	RO-1482402-00	22	2	SL-6040892-TN	54	17
KM-0000004-80	62	24	PC-0205010-A0	52	65	RO-1542401-00	10	8	SL-6040892-TN	54	17
KX-0000003-20	62	33	PC-022403E-00	42	33	RO-1952401-00	10	28	SL-6040892-TN	54	56
KX-0000003-30	62	52	PJ-0205000-01	42	33	SB-1080005-00	10	8	SL-6040892-TN	14	35
MC-2005313-0T	70	1	PJ-0320525-03	52	64	SB-1080005-00	14	14	SL-6040892-TN	14	25
MC-2005313-00	8	45	PJ-0320525-03	40	20	SB-1100013-00	4	45	SL-6040892-TN	14	28
MDF-RX1600C0	70	9	PJ-0460525-03	40	20	SB-1100024-00	4	41	SL-6040892-TN	14	30
M3801-476-000	62	9	PJ-0460525-03	48	20	SB-1120001-00	4	41	SL-6040892-TN	36	5
M4206-461-000	62	14	PJ-0460525-03	18	48	SB-1300002-00	16	13	SL-6040892-TN	36	9
M9029-580-0A0	62	50	PJ-0460525-03	24	22	SB-1300003-00	34	82	SL-6040892-TN	36	20
				24	21	SB-6160001-00	42	18	SL-6040892-TN	42	35
				38	51	SB-6040891-00	42	17	SL-6040892-TN	54	24
				54	33	SB-6040892-00	20	27	SL-6040892-TN	54	28
				12	8	SB-6040892-00	34	20	SL-6040892-TN	54	30
				12	27						

NUMERICAL INDEX OF PARTS

索引

PART NO 品番	PAGE 頁	REF NO	PART NO 品番	PAGE 頁	REF NO	PART NO 品番	PAGE 頁	REF NO	PART NO 品番	PAGE 頁	REF NO
SL-6040892-TN	54	53	SL-6064092-TN	30	53	SM-6051000-SP	38	20	SM-8050412-TP	34	71
SL-6040892-TN	75	8	SL-6082092-TN	52	16	SM-6051202-TN	46	24	SM-8050502-TP	20	37
SL-6041092-TN	2	22	SL-6083092-TN	62	10	SM-6051202-TP	54	45	SM-8050592-TP	20	12
SL-6041092-TN	28	9	SM-0040801-SC	2	21	SM-6051402-TN	44	37	SM-8050592-TP	20	30
SL-6041092-TN	42	39	SM-0040801-SC	34	27	SM-6051402-TP	20	26	SM-8050602-TP	42	10
SL-6041092-TN	54	35	SM-0041001-SC	30	16	SM-6051402-TP	34	84	SM-8050812-TP	34	80
SL-6041292-TN	30	13	SM-0041001-SC	30	20	SM-6051402-TP	34	86	SM-8050812-TP	38	7
SL-6041292-TN	30	15	SM-0041001-SC	30	23	SM-6052502-TP	34	16	SM-8050812-TP	38	23
SL-6041292-TN	30	18	SM-0041001-SC	30	25	SM-6051602-TP	34	56	SM-8060602-TP	52	40
SL-6041292-TN	30	27	SM-0041001-SC	30	29	SM-6051802-TP	38	30	SM-8060802-TP	34	45
SL-6041292-TN	34	93	SM-0041001-SC	30	32	SM-6052010-SC	20	36	SM-8060802-TP	34	49
SL-6041292-TN	36	11	SM-0041001-SC	30	35	SM-6052502-TN	44	42	SM-8060802-TP	34	52
SL-6041292-TN	36	12	SM-0041001-SC	30	37	SM-6052502-TN	46	29	SM-8060812-TP	4	43
SL-6041292-TN	36	15	SM-0041001-SC	30	39	SM-6052502-TP	12	4	SM-8060812-TP	20	17
SL-6041292-TN	38	61	SM-0041001-SC	30	41	SM-6052502-TP	34	63	SM-8060812-TP	34	44
SL-6041292-TN	42	23	SM-0041001-SC	30	43	SM-6053002-TN	38	52	SM-8060812-TP	34	47
SL-6041292-TN	54	8	SM-0041001-SC	30	51	SM-6053002-TN	42	26	SM-8060812-TP	34	51
SL-6041292-TN	54	11	SM-0050801-SC	26	17	SM-6053002-TN	42	28	SM-8060812-TP	40	23
SL-6041292-TN	54	38	SM-0050801-SC	28	4	SM-6053002-TP	34	10	SM-8060812-TP	40	46
SL-6041492-TN	30	2	SM-0081001-SD	26	9	SM-6053002-TP	34	58	SM-8060812-TP	42	52
SL-6041492-TN	30	5	SM-1030801-SC	46	14	SM-6053502-TN	38	47	SM-8080812-TP	52	34
SL-6041492-TN	30	45	SM-1040801-SC	40	35	SM-6061002-TP	52	53	SM-9051203-SE	72	7
SL-6041492-TN	30	47	SM-1040801-SP	28	30	SM-6061202-TN	40	37	SM-9064053-SE	34	12
SL-6041692-TN	42	19	SM-1041001-SC	44	40	SM-6061202-TN	42	68	SM-9064053-SE	34	35
SL-6041692-TN	42	48	SM-1041201-SC	44	8	SM-6061402-TN	40	42	SM-9102003-SB	32	18
SL-6042592-TN	40	44	SM-1041201-SC	46	20	SM-6061402-TN	42	25	SQ-1110401-MZ	24	11
SL-6051092-TN	54	7	SM-1041601-SC	44	4	SM-6061602-TN	38	34	SQ-1110402-MZ	4	28
SL-6051092-TN	54	10	SM-1041601-SC	44	18	SM-6061602-TN	44	15	SQ-1110402-MZ	22	13
SL-6051092-TN	72	9	SM-1041601-SC	58	5	SM-6061602-TN	56	14	SQ-1110451-MZ	22	53
SL-6051292-TN	30	11	SM-1051201-SC	28	25	SM-6061602-TN	74	8	SQ-1120451-MZ	22	30
SL-6051292-TN	54	19	SM-1051201-SC	30	21	SM-6061602-TP	26	12	SS-1060210-TP	18	20
SL-6051292-TN	54	21	SM-1051201-SC	54	3	SM-6061602-TP	34	6	SS-1121010-SP	18	21
SL-6051292-TN	54	40	SM-1051452-TN	38	25	SM-6061610-SC	68	6	SS-1121010-SP	18	37
SL-6051492-TN	30	4	SM-1051601-SC	28	5	SM-6062502-TN	26	14	SS-1121010-SP	18	39
SL-6051492-TN	30	7	SM-1051601-SC	28	27	SM-6062502-TN	28	34	SS-2060210-SP	18	10
SL-6051492-TN	30	30	SM-1051601-SC	56	13	SM-6062502-TN	38	37	SS-2111010-TP	10	22
SL-6051492-TN	30	49	SM-1061401-SE	52	63	SM-6062502-TN	44	12	SS-2111010-TP	18	42
SL-6051492-TN	42	14	SM-1061601-SC	44	2	SM-6062502-TN	44	29	SS-2111010-TP	56	11
SL-6051492-TN	42	16	SM-1061601-SC	44	23	SM-6062502-TP	34	2	SS-4080620-TP	18	11
SL-6051692-TN	42	3	SM-1061652-TP	40	32	SM-6062502-TP	34	24	SS-4110515-SP	22	56
SL-6051692-TN	42	46	SM-1062052-TP	28	40	SM-6062502-TP	34	29	SS-4110715-SP	10	4
SL-6051692-TN	42	53	SM-4020601-SC	75	4	SM-6062502-TP	34	33	SS-4111215-SP	2	45
SL-6052092-TN	20	8	SM-4031001-SC	36	13	SM-6063002-TP	20	5	SS-4120615-SP	2	12
SL-6052092-TN	34	87	SM-4040801-SN	40	40	SM-6063002-TP	34	5	SS-4120615-SP	2	14
SL-6052592-TN	4	24	SM-4041201-SC	68	24	SM-6063502-TN	26	27	SS-4120615-SP	2	17
SL-6052592-TN	60	17	SM-4042001-SC	68	23	SM-6063502-TN	26	35	SS-4120615-SP	22	9
SL-6061042-TN	52	44	SM-4050801-SC	48	55	SM-6063502-TN	52	55	SS-4120615-SP	22	11
SL-6061292-TN	30	9	SM-4051001-SN	12	25	SM-6063502-TN	74	10	SS-4120615-SP	22	65
SL-6061292-TN	42	57	SM-4051001-SN	52	60	SM-6063502-TN	74	12	SS-4120915-SP	10	5
SL-6061492-TN	26	19	SM-4051405-SE	68	12	SM-6064002-TN	40	12	SS-4120915-SP	10	26
SL-6061492-TN	26	21	SM-4061255-SP	2	27	SM-6064002-TP	40	8	SS-4120915-SP	10	43
SL-6061492-TN	26	38	SM-5051400-SC	54	32	SM-6064002-TP	40	10	SS-4121215-SP	2	3
SL-6061492-TN	30	34	SM-6030802-TN	42	59	SM-6064002-TP	42	44	SS-4121215-SP	2	6
SL-6061492-TN	46	2	SM-6031010-SC	20	13	SM-6064502-TP	74	14	SS-4121215-SP	2	9
SL-6061492-TN	48	2	SM-6031202-TP	16	5	SM-6065002-TP	26	31	SS-4121215-SP	2	24
SL-6061492-TN	48	4	SM-6040602-TP	34	74	SM-6066052-TP	52	8	SS-4121215-SP	2	52
SL-6061492-TN	48	43	SM-6040602-TP	34	89	SM-6082002-TN	40	29	SS-4121215-SP	6	4
SL-6061492-TN	48	53	SM-6040650-TP	20	28	SM-6082002-TN	44	34	SS-4121215-SP	16	22
SL-6061492-TN	52	2	SM-6040650-TP	34	21	SM-6082002-TN	44	50	SS-4121415-SP	12	20
SL-6061492-TN	52	4	SM-6040802-TN	42	62	SM-6082002-TP	40	19	SS-4121615-SP	50	11
SL-6061492-TN	52	6	SM-6040802-TP	18	43	SM-6082002-TP	52	25	SS-4151415-SP	14	42
SL-6061492-TN	52	18	SM-6040802-TP	20	34	SM-6082502-TN	38	43	SS-4151415-SP	14	44
SL-6061492-TN	52	22	SM-6040860-TP	36	7	SM-6082502-TP	52	42	SS-6090420-SP	56	10
SL-6061492-TN	54	26	SM-6040860-TP	36	23	SM-6082502-TP	52	48	SS-6090670-TP	8	14
SL-6062092-TN	36	3	SM-6041002-TN	58	8	SM-6082502-TP	52	50	SS-6090670-TP	18	33
SL-6062092-TN	38	4	SM-6041150-TP	34	78	SM-6083002-TP	42	41	SS-6090910-SP	22	49
SL-6062092-TN	40	28	SM-6041202-TN	26	6	SM-6086002-TN	26	40	SS-6110480-SP	56	12
SL-6062092-TN	42	5	SM-6041202-TP	34	69	SM-6088502-TP	52	30	SS-6110480-SP	56	19
SL-6062092-TN	42	67	SM-6041602-TP	32	11	SM-6104502-TP	26	3	SS-6110610-TP	18	22
SL-6062092-TN	72	6	SM-6041602-TP	32	13	SM-6105502-TN	40	2	SS-6110610-TP	24	9
SL-6062592-TN	38	2	SM-6041602-TP	42	31	SM-6123002-TN	40	6	SS-6111052-TP	14	22
SL-6063042-TN	46	6	SM-6042002-TN	44	47	SM-8030412-TP	14	27	SS-6120620-TP	22	63
SL-6063092-TN	28	22	SM-6042002-TP	32	4	SM-8040310-SS	4	36	SS-6120940-SP	22	16
SL-6063092-TN	38	5	SM-6042002-TP	32	6	SM-8040310-SS	4	40	SS-6121050-SP	18	23
SL-6063592-TN	34	67	SM-6042002-TP	32	8	SM-8050412-TP	4	46	SS-6123010-SP	12	32

NUMERICAL INDEX OF PARTS

索引

PART NO 品番	PAGE 頁	REF NO	PART NO 品番	PAGE 頁	REF NO	PART NO 品番	PAGE 頁	REF NO	PART NO 品番	PAGE 頁	REF NO
SS-6151412-TP	2	30	WP-0430801-SC	44	9	WS-0410002-KP	32	15	137-66506	22	18
SS-6151412-TP	2	32	WP-0430801-SC	46	21	WS-0410002-KP	34	91	137-66605	22	20
SS-6151612-TP	4	26	WP-0430801-SC	58	6	WS-0451040-KP	12	29	137-67405	22	22
SS-7080510-TP	8	43	WP-0430801-SC	58	9	WS-0510002-KN	34	60	137-67603	22	15
SS-7090530-SP	8	39	WP-0450801-SD	32	9	WS-0510002-KN	38	49	138-70258	50	3
SS-7090710-SP	18	36	WP-0450801-SD	32	14	WS-0510002-KN	38	53	138-70258	64	24
SS-7090850-SP	14	18	WP-0450826-SC	12	30	WS-0510002-KN	44	44	138-89951	50	17
SS-7090920-SP	10	19	WP-0480856-SP	2	49	WS-0510002-KN	68	16	139-20509	2	16
SS-7110350-SP	22	19	WP-0480856-SP	56	16	WS-0610002-KN	28	36	139-20608	8	41
SS-7110510-SP	24	19	WP-0501046-SC	46	35	WS-0610002-KN	28	41	139-22208	2	11
SS-7110710-SP	8	21	WP-0510516-SD	12	10	WS-0610002-KN	52	9	139-22901	4	19
SS-7110710-SP	18	2	WP-0531000-SC	22	61	WS-0820002-KN	38	45	139-24501	8	13
SS-7110840-SP	50	18	WP-0531000-SD	34	11	WS-0822010-KP	52	26	139-24600	8	34
SS-7120710-SP	24	17	WP-0531000-SD	34	64	WS-0861410-KR	52	31	139-25102	8	38
SS-7150740-SP	22	21	WP-0531000-SD	38	21	WS-1020002-KN	26	4	139-40804	22	10
SS-7151210-SP	8	30	WP-0531000-SE	72	8	WS-1020002-KN	32	20	139-40903	22	57
SS-7681650-TP	4	8	WP-0531001-SC	2	51	WS-1020002-KN	40	4	139-41307	22	27
SS-8090530-TP	50	6	WP-0531001-SC	28	6	WS-1643202-KR	68	20	139-41604	22	43
SS-8110422-TP	8	33	WP-0531001-SC	28	28				139-41653	22	42
SS-8110422-TP	10	14	WP-0531001-SC	34	17	101-26803	22	58	139-41802	22	47
SS-8110422-TP	10	16	WP-0531001-SC	34	59	105-02300	50	8	142-08409	12	15
SS-8110520-TP	16	19	WP-0531001-SC	38	48	110-042J5	6	6	178-45009	62	30
SS-8110750-SP	16	23	WP-0531001-SC	44	38	110-17068	8	47			
SS-8150410-SP	10	40	WP-0531001-SC	44	43	110-73954	2	50	225-07701	8	42
SS-8150410-TP	8	23	WP-0531001-SC	46	25	110-91600	8	52	226-87701	34	81
SS-8150510-TP	8	29	WP-0531001-SC	46	30	112-73505	18	16	227-98607	14	41
SS-8150760-TP	14	19	WP-0550836-SC	70	27	114-09257	18	6	229-02506	12	5
SS-8150822-TP	4	12	WP-0611626-SP	34	3	114-09604	18	8	229-03108	4	9
SS-8150822-TP	4	20	WP-0611626-SP	34	7	114-09802	18	7	229-03157	4	5
SS-8150822-TP	8	4	WP-0611626-SP	34	25	115-28809	38	59	229-07505	12	12
SS-8150822-TP	8	9	WP-0611626-SP	34	30	119-11203	16	12	229-07554	12	11
SS-8150822-TP	8	12	WP-0611626-SP	44	13	131-60601	70	28	229-07604	12	13
SS-8150822-TP	8	36	WP-0621016-SD	16	27	131-68208	68	21	229-16506	16	17
SS-8151230-SP	8	55	WP-0621016-SH	18	29	131-70105	26	8	229-21605	14	10
SS-8152030-SP	10	23	WP-0621026-SP	10	53	133-01908	20	3	229-24906	24	4
SS-8152030-SP	10	44	WP-0641600-SC	26	28	133-01908	28	21	229-25002	24	3
SS-8152030-SP	10	47	WP-0641600-SC	26	36	133-02500	20	4	229-25101	22	51
SS-8660512-TP	10	11	WP-0641600-SC	38	35	133-02500	28	20	229-30309	68	14
SS-8660512-TP	10	30	WP-0641600-SC	38	38	137-05207	2	15	229-30408	68	10
SS-8660530-TP	4	18	WP-0641600-SC	52	56	137-07500	4	38	229-30507	68	9
SS-8660610-TP	4	6	WP-0641600-SC	74	15	137-14407	8	53	229-30556	68	15
SS-8660610-TP	16	24	WP-0641601-SC	20	6	137-14704	8	37	229-30705	68	7
SS-8660612-TP	8	15	WP-0641601-SC	26	13	137-14803	8	35	229-30804	68	5
SS-8660612-TP	40	25	WP-0641601-SC	26	15	137-15404	8	2	229-30903	68	4
SS-8660612-TP	42	51	WP-0641601-SC	26	32	137-15503	8	3	229-31000	68	3
SS-8660810-TP	4	14	WP-0641601-SC	28	35	137-15701	8	27	229-31109	68	2
SS-8660810-TP	12	19	WP-0641601-SC	28	42	137-15909	8	32	229-31307	52	59
SS-8681650-TP	4	7	WP-0641601-SC	34	13	137-16006	8	31	229-31307	68	11
SS-9091010-SP	12	17	WP-0641601-SC	34	34	137-16105	10	34	229-31406	68	8
SS-9110513-TP	10	31	WP-0641601-SC	34	36	137-16303	10	12	229-32800	70	5
SS-9111010-SP	12	28	WP-0641601-SC	38	56	137-16808	10	50	229-33006	70	10
SS-9151630-CP	10	18	WP-0641601-SC	40	13	137-16907	10	49	229-33105	70	11
SS-9151910-SN	16	25	WP-0641601-SC	40	38	137-17004	10	32	229-33204	70	12
			WP-0641601-SC	44	30	137-17400	10	36	229-50000	18	28
TA-0180401-M0	22	7	WP-0641601-SC	52	10	137-18705	8	19	229-50356	18	41
TA-0550604-R0	8	17	WP-0641601-SC	56	17	137-18754	8	18	229-50950	16	18
TA-0850604-R0	2	46	WP-0641601-SC	74	9	137-18804	8	20	235-17501	20	19
TA-1050504-R0	2	33	WP-0641601-SC	74	11	137-18903	8	16	235-17600	20	20
TA-1250406-R0	2	48	WP-0641601-SC	74	13	137-19000	8	10	235-17709	20	21
TA-1250406-R0	12	9	WP-0651646-SC	46	7	137-19000	10	25	235-17808	20	22
TA-1250406-R0	16	14	WP-0841600-SC	38	44	137-19109	8	56	236-04309	4	42
TA-1450404-R0	2	47	WP-0841601-SC	42	21	137-19208	8	57	250-23300	44	21
TA-1470704-R0	2	40	WP-0841601-SC	44	35	137-19307	8	58	260-23408	38	22
TA-2101002-R0	2	34	WP-0841601-SC	44	51	137-19406	8	59	262-11904	2	26
TA-2351004-R0	2	35	WP-0841601-SC	62	39	137-19505	8	60	262-12209	2	36
			WP-0852086-SC	26	41	137-19802	2	13	269-10604	68	25
WP-0220301-SC	75	5	WP-0852086-SC	52	27	137-28506	22	28	269-10653	68	1
WP-0320501-SC	14	36	WP-0852086-SC	52	32	137-30304	8	8			
WP-0320501-SC	46	15	WP-1052000-SC	32	19	137-51607	22	14	400-00046	62	19
WP-0371036-SD	56	20	WP-1052001-SC	26	5	137-65201	22	45	400-00046	64	36
WP-0410846-SC	56	15	WP-1052001-SC	40	3	137-65607	22	31	400-05393	62	34
WP-0430801-SC	34	22	WP-1221016-SP	52	80	137-65706	22	3	400-05393	64	33
WP-0430801-SC	34	75	WP-1612616-SE	68	19	137-65805	22	4	400-05394	62	35
WP-0430801-SC	34	90	WS-0410002-KN	34	76	137-65904	22	1	400-05394	64	34
WP-0430801-SC	44	5	WS-0410002-KP	32	10	137-66407	22	17	400-05401	62	23

NUMERICAL INDEX OF PARTS

索引

PART NO 品番	PAGE 頁	REF NO	PART NO 品番	PAGE 頁	REF NO	PART NO 品番	PAGE 頁	REF NO	PART NO 品番	PAGE 頁	REF NO
400-05401	64	51	400-85820	38	19	401-05139	66	27	401-16076	36	10
400-05404	62	44	400-85830	38	32	401-05140	66	29	401-16077	36	19
400-05706	62	27	400-86465	62	41	401-05141	66	41	401-16078	36	21
400-06515	4	39	400-86465	64	37	401-05142	66	42	401-16079	36	22
400-06516	4	35	400-86466	62	32	401-05143	66	43	401-16080	38	1
400-06625	14	38	400-86466	64	38	401-05144	66	28	401-16081	38	3
400-09095	10	51	400-86541	60	5	401-05145	66	4	401-16082	38	24
400-09236	38	26	400-88163	14	24	401-05146	66	5	401-16083	38	29
400-10443	20	33	400-88208	48	54	401-05147	66	6	401-16085	38	31
400-10477	14	26	400-88208	66	24	401-05148	66	7	401-16086	38	33
400-10478	14	9	400-89027	75	3	401-05149	66	9	401-16087	38	36
400-10509	14	2	400-89237	75	2	401-05150	66	10	401-16088	38	60
400-10511	14	4	400-90589	62	53	401-05151	66	19	401-16090	40	1
400-10512	14	5	400-90589	64	32	401-05152	66	20	401-16091	40	5
400-10512	14	32	400-91335	28	16	401-05153	66	21	401-16092	40	7
400-10513	14	6	400-91335	64	43	401-05154	66	22	401-16093	40	9
400-10514	14	7	400-93183	26	39	401-05155	66	23	401-16094	40	11
400-10515	14	8	401-05004	62	1	401-05156	66	34	401-16095	40	14
400-10521	14	11	401-05005	62	2	401-05157	66	35	401-16096	40	21
400-10522	14	12	401-05006	62	3	401-05158	66	36	401-16097	40	22
400-10523	14	13	401-05020	60	1	401-05159	66	39	401-16098	40	27
400-11758	42	42	401-05020	64	13	401-05160	66	40	401-16099	40	31
400-16908	14	23	401-05030	62	15	401-05161	66	25	401-16100	40	45
400-16908	64	28	401-05030	64	21	401-05162	66	26	401-16101	44	1
400-16911	14	34	401-05058	64	19	401-05163	66	3	401-16102	44	22
400-23624	20	16	401-05068	64	20	401-05164	66	44	401-16103	44	33
400-23635	38	16	401-05069	44	24	401-05165	14	15	401-16104	44	49
400-23644	38	15	401-05070	40	18	401-05165	66	37	401-16165	46	1
400-31485	64	50	401-05071	40	26	401-05166	66	30	401-16172	26	20
400-32219	42	13	401-05072	38	9	401-05166	72	2	401-16175	28	23
400-32229	38	18	401-05073	38	10	401-05167	28	44	401-16176	28	24
400-35024	60	16	401-05074	52	19	401-05168	64	29	401-16177	30	19
400-35137	42	34	401-05075	52	43	401-05169	34	92	401-16178	52	1
400-35143	52	36	401-05076	52	52	401-15898	28	19	401-16179	52	3
400-35147	52	38	401-05078	62	36	401-15899	32	2	401-16180	52	5
400-35314	42	37	401-05078	64	31	401-16033	26	1	401-16181	52	7
400-39896	52	28	401-05088	64	44	401-16034	4	29	401-16182	52	11
400-40256	20	18	401-05089	64	45	401-16036	20	1	401-16183	52	13
400-44823	70	30	401-05090	64	18	401-16037	20	2	401-16184	52	14
400-51320	62	40	401-05092	64	57	401-16038	20	11	401-16185	52	17
400-51320	64	35	401-05095	75	6	401-16039	18	40	401-16186	52	21
400-52937	4	23	401-05098	34	18	401-16040	18	26	401-16187	52	23
400-52937	64	55	401-05098	64	4	401-16041	20	25	401-16188	52	29
400-55174	10	9	401-05099	34	15	401-16042	20	29	401-16189	52	37
400-55175	10	15	401-05099	64	2	401-16044	32	1	401-16190	52	41
400-55176	10	10	401-05100	64	6	401-16045	32	3	401-16191	52	47
400-55297	70	29	401-05101	64	5	401-16046	32	5	401-16192	52	49
400-55355	62	4	401-05104	64	10	401-16047	32	7	401-16193	52	51
400-55356	62	5	401-05105	64	9	401-16048	32	12	401-16194	52	57
400-55357	62	6	401-05106	64	12	401-16049	34	1	401-16195	52	58
400-58397	64	48	401-05107	64	11	401-16050	34	4	401-16196	52	62
400-58398	64	47	401-05108	64	54	401-16051	34	9	401-16197	52	74
400-71944	20	7	401-05109	64	53	401-16053	34	23	401-16198	52	76
400-71944	42	1	401-05110	64	15	401-16054	34	28	401-16199	52	77
400-71944	64	1	401-05112	64	16	401-16055	34	32	401-16200	52	78
400-72028	16	28	401-05114	64	17	401-16056	34	38	401-16201	52	79
400-72166	34	62	401-05116	66	1	401-16057	34	39	401-16202	52	24
400-72228	20	15	401-05117	66	2	401-16058	34	42	401-16205	48	1
400-73679	64	14	401-05118	66	14	401-16059	34	46	401-16206	48	3
400-74011	52	15	401-05119	66	17	401-16060	34	48	401-16207	48	6
400-75985	2	20	401-05120	66	33	401-16061	34	50	401-16208	48	8
400-75985	30	26	401-05121	64	25	401-16062	34	54	401-16208	48	44
400-77991	42	22	401-05122	64	8	401-16063	34	55	401-16209	48	42
400-78113	20	14	401-05123	66	31	401-16064	34	57	401-16210	48	52
400-78163	60	2	401-05124	64	7	401-16065	34	61	401-16211	48	62
400-78168	60	9	401-05127	66	15	401-16066	34	65	401-16212	48	64
400-80799	60	3	401-05129	66	32	401-16067	34	66	401-16213	48	66
400-80800	60	4	401-05130	66	16	401-16068	34	70	401-16214	26	18
400-82736	62	37	401-05132	64	23	401-16069	34	79	401-16215	28	31
400-82736	64	30	401-05133	64	22	401-16070	34	83	401-16216	28	37
400-82758	62	17	401-05134	64	27	401-16071	34	85	401-16217	28	8
400-82758	64	52	401-05135	64	26	401-16072	36	2	401-16218	28	17
400-83666	60	7	401-05136	66	11	401-16073	36	4	401-16219	26	24
400-83668	60	6	401-05137	66	12	401-16074	36	6	401-16220	26	37
400-83960	60	10	401-05138	66	13	401-16075	36	8	401-16229	2	25

NUMERICAL INDEX OF PARTS

索引

PART NO 品番	PAGE 頁	REF NO	PART NO 品番	PAGE 頁	REF NO	PART NO 品番	PAGE 頁	REF NO	PART NO 品番	PAGE 頁	REF NO
401-16230	2	29	401-16480	54	34						
401-16231	2	31	401-16481	54	37						
401-16232	4	25	401-16482	54	39						
401-16233	4	1	401-16483	54	42						
401-16234	4	44	401-16484	54	46						
401-16235	4	30	401-16485	54	47						
401-16236	8	1	401-16486	54	49						
401-16238	14	1	401-16487	54	54						
401-16239	14	3	401-16488	54	55						
401-16240	14	20	401-16489	56	8						
401-16241	14	21	401-16490	56	9						
401-16242	14	29	401-16491	58	2						
401-16243	14	31	401-16518	52	35						
401-16244	14	40	401-16519	52	33						
401-16245	14	43	401-16545	54	1						
401-16246	18	47	401-16546	56	1						
401-16247	20	35	401-16547	58	1						
401-16248	20	39	401-16548	26	2						
401-16249	22	59	401-16683	70	2						
401-16250	22	60	401-16684	70	3						
401-16251	2	18	401-16685	70	4						
401-16257	24	18	401-16756	72	1						
401-16261	40	43	401-19074	30	36						
401-16401	30	1	401-19168	75	1						
401-16402	30	3	401-19293	72	5						
401-16403	30	6	401-19303	72	4						
401-16404	30	8									
401-16405	30	10									
401-16406	30	12									
401-16407	30	14									
401-16408	30	17									
401-16409	30	22									
401-16410	30	24									
401-16411	30	28									
401-16412	30	31									
401-16413	30	33									
401-16415	30	38									
401-16416	30	40									
401-16417	30	42									
401-16418	30	44									
401-16419	30	46									
401-16420	30	48									
401-16421	30	50									
401-16422	30	52									
401-16429	42	4									
401-16430	42	6									
401-16431	42	7									
401-16432	42	11									
401-16433	42	15									
401-16435	42	20									
401-16436	42	24									
401-16437	42	29									
401-16438	42	30									
401-16439	42	38									
401-16440	42	43									
401-16441	42	45									
401-16442	42	47									
401-16443	42	49									
401-16444	42	56									
401-16445	42	58									
401-16464	54	2									
401-16465	54	4									
401-16466	54	6									
401-16467	54	9									
401-16468	54	12									
401-16469	54	13									
401-16470	54	15									
401-16471	54	16									
401-16472	54	18									
401-16473	54	20									
401-16474	54	22									
401-16475	54	23									
401-16476	54	25									
401-16477	54	27									
401-16478	54	29									



JUKI®

JUKI 株式会社

〒206-8551 東京都多摩市鶴牧 2-11-1

縫製機器ユニット

TEL.042-357-2371(ダイヤルイン) FAX.042-357-2380

JUKI CORPORATION

SEWING MACHINERY BUSINESS UNIT
2-11-1, TSURUMAKI, TAMA-SHI,
TOKYO, 206-8551, JAPAN
PHONE:(81)42-357-2371
FAX:(81)42-357-2380

Copyright© 2012 JUKI CORPORATION
本書の内容を無断で転載、複写することを
禁止します。
All rights reserved throughout the world.

お問い合わせ、ご相談は

To order or for further
information,
please contact:

※このパーツリストは商品改良のため予告なく変更する事があります。

*The description covered in this parts list is subject to change for improvement of the commodity without notice.

※このパーツリストは 2012 年 1 月現在の商品仕様で編集したものです。

*This parts list is edited in accordance with the product specifications as of January 2012.

Printed in Japan